

CITY OF LOCUST GROVE

REGULAR MEETING AGENDA

MONDAY JUNE 5, 2023 – 6:00 P.M.

PUBLIC SAFETY BUILDING – 3640 HIGHWAY 42 S.

LOCUST GROVE, GA 30248

CALL TO ORDER Mayor Robert Price

INVOCATION Chief Derrick Austin

PLEDGE OF ALLEGIANCE Councilman Breedlove

APPROVAL OF THE AGENDA Mayor Robert Price (Motion Required)

PUBLIC COMMENTS Register with Clerk Before Meeting

- Presentation by Laura Luker with the Henry County Convention and Visitors' Bureau (CVB) on FY 2022 activities, expenditures, and plans/promotions for 2023

PUBLIC HEARING ITEMS None

APPROVAL OF THE MINUTES 4 Items

1. May 1, 2023, Regular Meeting Minutes (Motion Required)
2. May 1, 2023, Executive Session Meeting Minutes (Motion Required)
3. May 15, 2023, Workshop Meeting Minutes (Motion Required)
4. May 15, 2023, Executive Session Meeting Minutes (Motion Required)

ACCEPTANCE OF THE FINANCIAL STATEMENT 2 Items

5. December 2022 – Financial Statement (Motion Required)
6. January 2023 - Financial Statement (Motion Required)

UNFINISHED BUSINESS/ACTION ITEMS 2 Items

7. Resolution to award the contract for professional consultant services associated with the review and updating of the city's Impact Fee program (Motion Required)
8. Ordinance to amend the FY 2023 Operating and Capital Improvements Budget for the 1st Quarter (Motion Required)

NEW BUSINESS/ACTION/DISCUSSION ITEM 2 Items

9. Special Event permit request from TNT Fireworks for a fireworks sale to benefit Rainbow Girls, a non-profit organization (Motion Required)
10. Resolution to authorize and enter into a lease agreement with United Bank for the purpose of leasing heavy equipment (Motion Required)

CITY MANAGER'S COMMENTS Tim Young

11. Postponement of July 17, 2023, Council Workshop to July 24, 2023

COUNCIL COMMENTS Council

MAYOR'S COMMENTS Mayor Robert Price

EXECUTIVE SESSION – (IF NEEDED)

ADJOURN

POSTED AT CITY HALL –May 31, 2023, at 16:30

ADA Compliance: Individuals with disabilities who require certain accommodations to allow them to observe and/or participate in this meeting, or who have questions regarding the accessibility of the meeting, or the facilities are required to contact the City Clerk at (770) 957-5043 promptly to allow the City to make reasonable accommodations for those persons. Public Comment may be limited to no more than ten (10) minutes with up to 3 minutes per requesting applicant to speak. Please register your NAME and ADDRESS prior to the beginning of the meeting with the City Clerk.

**City of Locust Grove
Council Meeting Minutes
Public Safety Building – Courtroom Chamber
3640 Highway 42 S. – Locust Grove, GA 30248
Monday, May 1, 2023
6:00 PM**

Members Present:	Staff Present:
Robert Price – Mayor	Tim Young – City Manager
Carlos Greer – Councilman	Bert Foster – Assistant City Manager
Willie Taylor – Councilman	Misty Spurling – City Clerk
Keith Boone – Councilman/Pro Tem	Jennifer Adkins – Assistant City Clerk
Vincent Williams – Councilman	Daunté Gibbs – Community Development Director
Rod Shearouse – Councilman	Jack Rose – Public Works Director
Rudy Breedlove – Councilman	Derrick Austin - Police Chief
	Andy Welch – Attorney
	Staff not present:
	Colleen Cook – Main Street Director

Mayor Price called the meeting to order at 6:00 PM

Invocation given by City Manager Tim Young.

Councilman Williams led the Pledge of Allegiance.

APPROVAL OF AGENDA –

Mayor Price asked for a motion. Councilman Greer made the motion to approve the agenda.

RESULT	APPROVED
MADE MOTION	COUNCILMAN GREER
2 ND MOTION	COUNCILMAN BOONE
VOTE	MOTION CARRIED - ALL IN FAVOR

PUBLIC COMMENTS – NONE

PUBLIC HEARING ITEMS – NONE

APPROVAL OF THE MINUTES –

1. APRIL 3, 2023- REGULAR MEETING MINUTES –

Mayor Price asked for a motion. Councilman Greer made the motion to approve the April 3, 2023, regular meeting minutes.

RESULT	APPROVED APRIL 3, 2023, REGULAR MEETING MINUTES
MADE MOTION	COUNCILMAN GREER
2 ND MOTION	COUNCILMAN BOONE
FAVOR	MOTION CARRIED – ALL IN FAVOR

2. APRIL 3, 2023- EXECUTIVE SESSION MEETING MINUTES –

Mayor Price asked for a motion. Councilman Williams made the motion to approve the April 3, 2023, executive session meeting minutes.

RESULT	APPROVED APRIL 3, 2023, EXECUTIVE SESSION MEETING MINUTES
MADE MOTION	COUNCILMAN WILLIAMS
2 ND MOTION	COUNCILMAN GREER
FAVOR	MOTION CARRIED – ALL IN FAVOR

3. APRIL 17, 2023- WORKSHOP MEETING MINUTES –

Mayor Price asked for a motion. Councilman Taylor made the motion to approve the April 17, 2023, workshop meeting minutes.

RESULT	APPROVED APRIL 17, 2023, WORKSHOP MEETING MINUTES
MADE MOTION	COUNCILMAN TAYLOR
2 ND MOTION	COUNCILMAN WILLIAMS
FAVOR	MOTION CARRIED – ALL IN FAVOR

4. APRIL 17, 2023- EXECUTIVE SESSION MEETING MINUTES –

Mayor Price asked for a motion. Councilman Breedlove made the motion to approve the April 17, 2023, executive session meeting minutes.

RESULT	APPROVED APRIL 17, 2023, EXECUTIVE SESSION MEETING MINUTES
MADE MOTION	COUNCILMAN BREEDLOVE
2 ND MOTION	COUNCILMAN WILLIAMS
FAVOR	MOTION CARRIED – ALL IN FAVOR

ACCEPTANCE OF THE FINANCIAL STATEMENT – NONE – FY 2022 final adjustments pending from audit.

UNFINISHED BUSINESS/ACTION ITEMS –

5. Ordinance for adoption of a new zoning map incorporating map amendments, areas annexed into the city August 1, 2016, and new zoning districts (Tabled from April 3, 2023) –

Mayor Price asked for a motion. Councilman Breedlove made the motion to approve the request by approving ordinance # **23-05-038.**

RESULT	APPROVED ORDINANCE #23-05-038
MADE MOTION	COUNCILMAN BREEDLOVE
2 ND MOTION	COUNCILMAN SHEAROUSE
FAVOR	MOTION CARRIED – ALL IN FAVOR

6. Ordinance to amend the city’s Future Land Use Map designation from Office and Medium Density Residential to Community Commercial for multiple tracts located on highway 42 and Tanger Boulevard –

Mayor Price asked for a motion. Councilman Breedlove made the motion to approve the request by approving ordinance #23-05-039.

RESULT	APPROVED ORDINANCE #23-05-039
MADE MOTION	COUNCILMAN BREEDLOVE
2 ND MOTION	COUNCILMAN SHEAROUSE
FAVOR	MOTION CARRIED – ALL IN FAVOR

7. **Ordinance for rezoning from OI (office/institutional), RM (residential multi-family) and PD (planned development) to C-2 (general commercial) for 29.62 +/- acres (Parcel IDs: #129-01004000, 129-01002000, 129-01003000, and 130-01002006) in LL 166 of the 2nd district on Highway 42 and Tanger Boulevard –**

Daunté stepped forward to comment. Daunté said the conditions were amended to include Councilman Greer’s request at the last meeting for the applicant to coordinate deeded right-of-way for future widening of Hwy 42. Daunté said staff recommends approval with conditions and read aloud conditions one through five.

Councilman Breedlove said he wants to amend staff conditions to add one additional condition number six (read aloud): *The owner shall coordinate with the City of Locust Grove the installation of an 8’ multi-use path linking the development to the city’s Trail Network that will extend to Barnes Station.*

Mayor Price asked for a motion. Councilman Breedlove made the motion to approve the request by approving ordinance #23-05-040 as amended.

RESULT	APPROVED ORDINANCE #23-05-040 AS AMENDED
MADE MOTION	COUNCILMAN BREEDLOVE
2 ND MOTION	COUNCILMAN GREER
FAVOR	MOTION CARRIED – ALL IN FAVOR

8. **Ordinance to approve a variance request to allow for a master sign plan located on the west side of the intersection of Tanger Boulevard and Highway 42 (Parcel IDs: – #129-01004000, 129-01002000, 129-01003000, and 130-01002006) -**

Mayor Price asked for a motion. Councilman Shearouse made the motion to approve the request by approving ordinance # 23-05--041.

RESULT	APPROVED ORDINANCE #23-05-041
MADE MOTION	COUNCILMAN SHEAROUSE
2 ND MOTION	COUNCILMAN BOONE
FAVOR	MOTION CARRIED – ALL IN FAVOR

9. **Ordinance to approve a Conditional Use request to allow gravel-surfaced truck/tractor-trailer parking on Bethlehem Road west of Highway 42 (Parcel IDs: 111-01013015, 111-0103016, and 111-0103020) –**

Daunté Gibbs said this request was previously discussed as part of a public hearing and the council made suggestions for additional conditions to be added. Daunté said staff recommends approval with conditions and read aloud conditions one through six as follows:

1. *The applicant shall submit a photometric plan to the Community Development Director for review prior to the issuance of any land disturbance or building permit. All parking areas and entry/exit gates will be adequately lit.*
2. *All entry/exit points to the truck parking area shall be secured with fencing, gates, and/or security.*
3. *In addition to required buffering, the applicant shall install opaque privacy fencing eight (8) feet in height around the perimeter of the parking lot.*
4. *The applicant shall coordinate with the LGPD for the installation of flock cameras.*
5. *The gravel surface shall always be kept in a neat and orderly condition and is subject to an annual inspection from the City Code Enforcement Officer.*
6. *No tractor-trailer or any other vehicle shall be occupied overnight.*

Councilman Boone said there was previous discussion about the road coming through the property and discussion took place. Daunté said there will not be any liability with the city in respect to the property owner. Councilman Williams asked if the owner of the property is present tonight. Mayor Price said no. Boone made a motion to postpone the item. Andy said if postponed, the council must set a date for revisiting. If the council tables the request, the council can bring it back up at any time (in a reasonable period of time due to posting requirements).

Mayor Price asked for a motion. Councilman Boone made the motion to table the request.

RESULT	TABLED
MADE MOTION	COUNCILMAN BOONE
2 ND MOTION	COUNCILMAN SHEAROUSE
FAVOR	MOTION CARRIED –FIVE IN FAVOR (TAYLOR, BOONE, WILLIAMS, SHEAROUSE, BREEDLOVE) AND ONE OPPOSED (GREER)

Andy said with the request being tabled, it can be brought back at any time; however, a decision would have to be made (without lingering on) because it is a zoning matter, and a public hearing was held.

Councilman Greer said he thinks the request should be postponed for a definite date. Discussion took place with no substitute or additional motion.

10. Ordinance to approve the final plat for Bridle Creek Phase 2A subdivision located on Highway 42 in Parcel #147-01009016 –

Mayor Price asked for a motion. Councilman Greer made the motion to approve the request by approving ordinance # 23-05--042.

RESULT	APPROVED ORDINANCE #23-05-042
MADE MOTION	COUNCILMAN GREER
2 ND MOTION	COUNCILMAN WILLIAMS
FAVOR	MOTION CARRIED – ALL IN FAVOR

11. Ordinance to approve the final plat for Collinswood Phase II (LG Griffin Pod D) located on Kirkland Dr. in Parcel #130-01002012 –

Mayor Price asked for a motion. Councilman Shearouse made the motion to approve the request by approving ordinance # 23-05--043.

RESULT	APPROVED ORDINANCE #23-05-043
MADE MOTION	COUNCILMAN SHEAROUSE
2 ND MOTION	COUNCILMAN GREER
FAVOR	MOTION CARRIED – ALL IN FAVOR

12. Ordinance to approve a final plat for Cedar Ridge (Pod D Phase I) located on Tanger Blvd, (Parcel ID #130-01005000) –

Mayor Price asked for a motion. Councilman Shearouse made the motion to approve the request by approving ordinance # 23-05--044.

RESULT	APPROVED ORDINANCE #23-05-044
MADE MOTION	COUNCILMAN SHEAROUSE
2 ND MOTION	COUNCILMAN WILLIAMS
FAVOR	MOTION CARRIED – ALL IN FAVOR

13. Resolution approving the architectural plans submitted for The Shops at Indian Creek –

Mayor Price asked for a motion. Councilman Shearouse made the motion to approve the request by approving resolution # 23-05--045.

RESULT	APPROVED RESOLUTION #23-05-045
MADE MOTION	COUNCILMAN SHEAROUSE
2 ND MOTION	COUNCILMAN BREEDLOVE
FAVOR	MOTION CARRIED – ALL IN FAVOR

14. Resolution approving the architectural plans submitted for the remodel of an existing structure located at 4971 Bill Gardner Parkway –

Mayor Price asked for a motion. Councilman Williams made the motion to approve the request by approving resolution # 23-05--046.

RESULT	APPROVED RESOLUTION #23-05-046
MADE MOTION	COUNCILMAN WILLIAMS
2 ND MOTION	COUNCILMAN TAYLOR
FAVOR	MOTION CARRIED – ALL IN FAVOR

NEW BUSINESS/ACTION/DISCUSSION ITEMS –

15. Ordinance to amend Section 2.04.010 of Title 2, Chapter 4 of the City of Locust Grove Code of Ordinances which provides for compensation -

Tim Young stepped forward and said this is a request previously discussed for staff to look at the compensation for the change in the Mayor and Council salaries. Tim reviewed the increases [Council increase to \$1,000 per month, and Mayor increase to \$1,200 per month]. Andy said the ordinance says this will be effective immediately; however, need to amend the ordinance to be effective January 1, 2024.

Councilman Williams said the mayor’s salary should be \$1,500 per month (\$18,000 annually). Andy said the council needs to make a motion to amend.

Mayor Price asked for a motion. Councilman Breedlove made the motion to amend to change the mayor’s salary to \$18,000 annually and amend to change effective date to January 1, 2024, thus approving the request by approving ordinance #23-05-047.

Councilman Shearouse made a comment for those members who have been here long term deserve the increase; however, Shearouse said he does not agree with the increase for those of recent tenure. Greer said he is recusing himself from voting. Andy asked Greer if there is a basis for his recusal and Greer said no.

RESULT	APPROVED ORDINANCE #23-05-047
MADE MOTION	COUNCILMAN BREEDLOVE
2 ND MOTION	COUNCILMAN WILLIAMS
FAVOR	MOTION CARRIED – FOUR IN FAVOR (TAYLOR, BOONE, BREEDLOVE, WILLIAMS) ONE RECUSED (GREER) AND ONE OPPOSED (SHEAROUSE)

CITY MANAGER’S COMMENTS –

Mr. Young gave an update staff is working on FEMA submittals and finalizing the audit with the accountants in preparation for the auditors’ final steps. Tim said he will have information soon on the CID for the area of public improvements. Nothing further.

COUNCIL COMMENTS –

Councilman Greer asked Jack about the status of the replacement of the signs on Tanger, turning off Highway 42. Greer said he mentioned it at the last council meeting. Jack said he will check on it, but it may be GDOT responsibility.

MAYOR’S COMMENTS – NONE

EXECUTIVE SESSION – PERSONNEL & LITIGATION

Motion to go into executive session to discuss pending and/or threatened litigation and personnel matters by Councilman Breedlove and seconded by Councilman Williams. Motion Carried All in favor 6:31 PM.

At 8:09 PM, motion to come back into regular session made by Councilman Shearouse and seconded by Councilman Breedlove.

REGULAR SESSION RECONVENED –

Mayor Price said he has an item for discussion that he forgot to bring up in his comments. Mayor said there is a need for paving the main drive in the cemetery down to where it meets at Frances Ward Drive. There are funds in the cemetery account to cover the costs and Tim has the information for review. Tim reviewed

two quotes: Onsite Paving for \$15,515 and Stockbridge Paving for \$13,200. Tim said this will be the main section from Claude Gray down to Frances Ward. We will also replace the chains with permanent gates.

Greer asked if we need to include the other areas in the cemetery for repair and Mayor Price said we don't have enough funds to do additional repairs/paving right now.

Motion to add item for paving the cemetery street to the agenda by Councilman Boone and seconded by Councilman Williams.

ADD ITEM –

16. Cemetery – Paving of street section (from Claude Gray to Frances Ward)

Mayor Price asked for a motion. Councilman Boone made the motion to approve the request by approving the proposal from Stockbridge Paving in the amount of \$13,200.

RESULT	APPROVED FOR STOCKBRIDGE PAVING
MADE MOTION	COUNCILMAN BOONE
2 ND MOTION	COUNCILMAN GREER
FAVOR	MOTION CARRIED – ALL IN FAVOR

ADJOURNMENT –

Mayor Price asked for a motion to adjourn. Councilman Boone made the motion to adjourn.

RESULT	APPROVED – ADJOURN MEETING
MADE MOTION	COUNCILMAN BOONE
2 ND MOTION	COUNCILMAN BREEDLOVE
FAVOR	MOTION CARRIED MEETING ADJOURNED @ 8:18 PM.

Notes taken by:

Misty Spurling
City Clerk

**City of Locust Grove
 Council Workshop Meeting Minutes
 Public Safety Building – 3640 Highway 42 S.
 Locust Grove, GA 30248
 Monday, May 15, 2023
 6:00 PM**

Members Present:	Staff Present:
Robert Price – Mayor	Tim Young – City Manager
Keith Boone – Councilman/Pro Tem	Bert Foster – Assistant City Manager
Vincent Williams – Councilman	Misty Spurling – City Clerk
Willie Taylor – Councilman	Jennifer Adkins – Assistant City Clerk
Rod Shearouse - Councilman	Jack Rose – Public Works Director
Rudy Breedlove - Councilman	Daunté Gibbs – Community Development Director
Carlos Greer – Councilman	Colleen Watts – Main Street Manager
	Derrick Austin – Police Chief
	Brooke White –SWWW Attorney
	Staff not present:
	Andy Welch – Attorney

Mayor Price called the meeting to order at 6:00 PM.

Invocation given by Assistant City Manager Bert Foster

Councilman Shearouse led the Pledge of Allegiance

APPROVAL OF AGENDA –

Mayor Price asked for a motion. Councilman Boone made the motion to approve the agenda as amended.

RESULT	APPROVED AGENDA
MADE MOTION	COUNCILMAN BOONE
2 ND MOTION	COUNCILMAN BREEDLOVE
VOTE	MOTION CARRIED - ALL IN FAVOR

PUBLIC COMMENTS – NONE

PUBLIC HEARING ITEMS – NONE

OLD BUSINESS/ACTION ITEMS – NONE

NEW BUSINESS/ACTION ITEMS –

- 1. Resolution to ratify the final rankings for firms wishing to provide on-call engineering services to the city –**

Bert stepped forward and reviewed the item for on-call engineering services. Bert said this is to assist with the design and review of the road projects and other public improvements. We received eight responses; six of which are willing to perform all the requested services specified. Two of the respondents requested consideration for transportation projects only. Bert reviewed the order of preference based on staff (Tim, Bert, Daunté, and Misty) review that took place on April 25, 2023.

There was a question by Councilman Boone on the order of the respondents, and Bert clarified that the reviewing staff ranked with the 1 being the highest and 6 being the lowest.

Mayor Price asked for a motion. Councilman Taylor made the motion to approve the request by approving resolution **#23-05-048**.

RESULT	APPROVED RESOLUTION # 23-05-048
MADE MOTION	COUNCILMAN TAYLOR
2 ND MOTION	COUNCILMAN SHEAROUSE
VOTE	MOTION CARRIED - ALL IN FAVOR

Tim made a comment that the applicant (Zack Hinton, Jr.) is here tonight if the council wanted to discuss the Conditional Use request for gravel-surfaced truck/tractor-trailer parking that was tabled at the last meeting.

Attorney Brooke White said the item will need to be added to the agenda if the council wants to discuss.

Mayor Price asked for a motion. Councilman Boone made the motion to add item to the agenda.

RESULT	APPROVED ADD ITEM
MADE MOTION	COUNCILMAN BOONE
2 ND MOTION	COUNCILMAN WILLIAMS
VOTE	MOTION CARRIED - ALL IN FAVOR

ADD ITEM –

2. Conditional Use request to allow gravel-surfaced truck/tractor-trailer parking on Bethlehem Road west of Highway 42 (Parcel IDs: 111-01013015, 111-01013016, and 111-01013020). –

Councilman Greer said he was not aware this would be brought back for discussion tonight and said he is not ready to act [on the request].

Mayor Price asked the applicant, Zack Hinton, Jr.["Zip"] to step forward. Mr. Hinton stepped forward to comment.

Councilman Williams asked Zip if he is familiar with the proposed Bethlehem Road Interchange and asked him why this location for this type of request. Mr. Hinton said “yes, he is familiar with the Interchange and said he wanted to proceed because he’s not aware of when the State would begin the project for that improvement.” Discussion took place about the plan.

Councilman Shearouse asked if the property would be more valuable if developed now. Hinton said he tried to develop this two years ago before Bethlehem Road was under discussion. It would have benefited him if the interchange didn’t come.

Daunté read the conditions aloud for review. Boone asked if the condition for overnight sleeping includes prohibiting daytime sleeping as well. Daunté said the council originally said only overnight sleeping but can be amended to include daytime sleeping if necessary. Daunté said the state law requires mandatory rest and discussion took place.

Councilman Greer asked if this would require a daily parking pass. Zack said this will be set up on a monthly parking pass only. A discussion took place about Mr. Hinton’s additional parking location in Jackson and Zip said that location is thriving. Nothing further.

Mayor Price asked for a motion. Councilman Boone made the motion to approve the request by approving ordinance #23-05-049.

RESULT	APPROVED ORDINANCE #23-05-049
MADE MOTION	COUNCILMAN BOONE
2 ND MOTION	COUNCILMAN TAYLOR
VOTE	MOTION CARRIED – FIVE IN FAVOR (BOONE, TAYLOR, WILLIAMS, GREER, BREEDLOVE) AND ONE OPPOSED (SHEAROUSE)

CITY OPERATION REPORTS / WORKSHOP DISCUSSION ITEMS -

MAIN STREET OPERATIONS – COLLEEN COOK

Ms. Cook gave an update the DDA met about future installations of artwork at Cleveland Street. We are in the process of planning summer activities with fun things ahead. Bluegrass music is every Saturday downtown, and the Artisan Market [Makers Market] is every other Saturday. Nothing further.

PUBLIC SAFETY OPERATIONS – CHIEF AUSTIN

Chief Austin reviewed the monthly report and gave an update total collected in April 2023 was \$70,844.00. The department completed 341 training hours in April, and we had 50 new cases for investigation and cleared 39 of those cases.

There was a robbery at Wal-Mart and the suspect has been arrested. The victim was not injured. Nothing further.

PUBLIC WORKS – JACK ROSE

Mr. Rose said the plant operation is good. The second phase of the paving project will begin soon, and we are continuing with normal day-to-day maintenance. Tim asked if the finger paint (artwork) was removed at Chase Maddox Park facilities and Jack said yes, about 90% was removed. Chief Austin said it was a group of small kids accompanied by a teenage adult. The Chief said it was not intentional vandalism, but it was a big mess. Nothing further.

ADMINISTRATION –BERT FOSTER

Mr. Foster gave an update for the Peeksville Road Extension and the Bill Gardner Parkway modifications. C.W. Matthews will begin installation of the 10-inch water line portion for the extra lane on Highway 42 and the paving project for Phase II will begin soon. Ronnie Glaze is serving as the project manager for the scatter garden/veteran’s memorial, and we met with the grading contractors to discuss options and public works will assist with erosion sedimentation. We met onsite with Georgia Power about the overhead powerline and the tree service company is ready to remove the four pecan trees in that area.

Greer asked what the meeting with the contractors was about. Bert said for grading and Greer said he thought the council and staff agreed for Roberts Hauling to proceed with grading at a previous meeting. Bert said we needed to get additional bids.

Bert gave an update for the downtown corridor study and the signal at Bethlehem Road and Highway 42. The total costs for the City Hall renovations are \$300,000 and the supplies have been ordered. We will be

relocating the water department across the hall until repairs are complete. We met with Henry County and their consultants last week about the MMIP project and the preliminary report was submitted to Henry County. Nothing further.

COMMUNITY DEVELOPMENT OPERATIONS –DAUNTÉ GIBBS

Mr. Gibbs gave an update that the department has issued a total of eight 457 permits (including 75 new house permits) for 2023. We have issued 55 COs [27 residential, and 28 commercials] and 302 business licenses issued so far for 2023.

3. CarMax Landscape Plan – discussion only

Shearouse recused himself from discussion and exited the meeting.

Daunté said this item is for discussion only and not for action and review of the plan presented on the overhead screen. Since the last meeting, representatives with CarMax met with staff to discuss the concerns that were previously mentioned. The creek that runs through the property will be protected and they agreed to move the carwash further into their property.

Greer said the applicant originally said they could not plant trees because of the slope in the property, and asked if the cause of the slope is because they are moving dirt.

Scott stepped forward to comment and said yes, the problem is being created with grading.

Steve Hudan with CarMax stepped forward. Steve said the grading is in the direction of the retention pond and said yes, the problem is being created from the grading. Nothing further.

Shearouse returned to the meeting.

Mayor Price asked for a motion. Councilman Boone made the motion to add item to the agenda.

RESULT	APPROVED ADD ITEM
MADE MOTION	COUNCILMAN BREEDLOVE
2 ND MOTION	COUNCILMAN GREER
VOTE	MOTION CARRIED - ALL IN FAVOR

ADD ITEM –

4. Request for approval to dig a well at 351 South Singley Drive –

Daunté said this is a request to dig a well because the subject property is not located within the water service area of the city nor the Henry County Water authority. Daunté said all inspections have been passed to date and all required permits have been issued. Staff recommends approval.

Mayor Price asked for a motion. Councilman Breedlove made the motion to approve the request by approving ordinance #23-05-050.

RESULT	APPROVED ORDINANCE #23-05-050
MADE MOTION	COUNCILMAN BREEDLOVE
2 ND MOTION	COUNCILMAN SHEAROUSE
VOTE	MOTION CARRIED - ALL IN FAVOR

ARCHITECTURAL REVIEW BOARD (ARB) – NONE

CITY MANAGER’S COMMENTS –TIM YOUNG

5. Community Improvements District “The Cubes” timeline and process overview –

Tim said the purpose of this is to provide for certain infrastructure in areas [mainly Price Road] relocate its current unpaved status in a new alignment to Bethlehem Road. The developer will be building the road and reimbursed by the CID. We need to appoint two board members and review other requirements. Staff have met with all parties and the next step is to send notices to tax commissioners and property owners. This should be finalized by mid to end July 2023.

Breedlove asked, “What is the CID”? Tim said the CID is a self-taxing entity (Community Improvement District). The main purpose for the city is the realignment and relocation of Price Road. “The Cubes” is the branded name, mainly on the west coast. Tim said the whole development is “The Cubes.” Tim also noted that if there were a name the Council would like in lieu of “The Cubes” to let us know.

Shearouse asked if the developer is in favor. Tim said the developer spearheaded off this and the CID allows them to self-impose a property tax. Shearouse asked how this will work when Locust Grove has a property tax. Tim said this doesn’t preclude a city property tax, they will pay taxes to the city and to themselves in the CID.

6. 1st Quarter Budget Amendment –

Tim said the revenues were updated for Insurance Premium Tax since the revised returns and we also have a healthy flow of TAVT revenue, averaging (\$28,000-\$29,000) month. We added a scholarship for leadership henry and other increases including a proposed COLA and the incorporation of additional increase in the healthcare plan increase of 30% versus 10-12% in the original forecast budget.

7. FEMA emergency expenditures – January 12, 2023, tornado event –

Tim said we are still finalizing requests and have submitted everything except for equipment. We are expecting to be reimbursed around \$100,000 for damages and should have the final figure by June.

8. SS4A (Safe Streets 4 All) – Henry County –

This was briefly mentioned at the HCMA dinner in Hampton, for a grant application to create a safety plan. This would require a 20% match by the local government(s) to perform a study estimated at \$250,000 by their staff. The city share should be no more than \$2,750 based on population share.

9. Direction Signage Plan for Trails –

This is a request is a request from Henry County to join them and the cities on a comprehensive wayfinding signage program for the new HC Trail Plan program. The proposed bid of \$90,000 to conduct the work, and our share (based on population) would be around \$3,375, which is higher due to the lack of any federal funding provided by grant as in the Safe Streets program.

COUNCIL COMMENTS - NONE

MAYOR’S COMMENTS – NONE

EXECUTIVE SESSION – PERSONNEL

Motion to go into executive session to discuss personnel items by Councilman Boone and seconded by Councilman Breedlove. Motion Carried All in favor 7:10 PM.

At 7:29 PM, motion to come back into regular session made by Councilman Shearouse and seconded by Councilman Boone.

ADJOURNMENT-

Mayor Price asked for a motion to adjourn. Councilman Williams made the motion to adjourn.

RESULT	ADOPTED
MADE MOTION	COUNCILMAN WILLIAMS
2 ND MOTION	COUNCILMAN BOONE
VOTE	MOTION CARRIED - ALL IN-FAVOR MEETING ADJOURNED @ 7:30PM.

Notes taken by:

Misty Spurling, City Clerk



Community Development Department

P. O. Box 900
Locust Grove, Georgia 30248
Phone: (770) 957-5043
Facsimile (770) 954-1223

Item Coversheet

Item: **A Resolution to award the bid for professional consultant services associated with the review and updating of the City’s Impact Fee Program**

Action Item: Yes No

Public Hearing Item: Yes No

Executive Session Item: Yes No

Budget Item: **Development Impact Fees (PSB)**

Date Received: **May 16, 2023**

Workshop Date: **NA**

Regular Meeting Date: **June 5, 2023**

Discussion:

The City recently sought the services of a professional consultant to assist with the necessary updates to the City’s Impact Fee Program. A careful study of the existing Impact Fee Program, along with an analysis of the current Capital Improvement Element (“CIE”), will determine the specific updates that will need to be made.

Bill Ross with Ross Associates worked on the original Impact Fee Program and agreed to revisit the program to ensure the City is compliant with the Georgia Development Impact Fee Act. Given the specialized nature of this project, Mr. Ross estimates his fees not being in excess of \$79,500.

Recommendation:

Staff recommends awarding the bid to:

**Ross + Associates
Attn: Mr. Bill Ross
340 N. Main Street
Madison, GA 30650**

RESOLUTION NO. _____

A RESOLUTION TO ACCEPT THE BID FOR CONSULTANT SERVICES FOR STUDYING AND UPDATING THE CITY’S IMPACT FEE PROGRAM; TO AUTHORIZE THE MAYOR, THE CITY MANAGER AND THE ASSISTANT CITY MANAGER TO ENGAGE IN THE NECESSARY STEPS TO EFFECTUATE THIS UPDATE; TO AUTHORIZE THE CITY ATTORNEY TO REVIEW ANY AND ALL DOCUMENTS RELATED TO THIS PROJECT; TO AUTHORIZE THE CITY CLERK TO ATTEST ANY AND ALL SIGNATURES RELATED TO SAID PROJECT; TO REPEAL INCONSISTENT RESOLUTIONS; TO PROVIDE FOR AN EFFECTIVE DATE; AND FOR OTHER PURPOSES.

WITNESSETH:

WHEREAS, the City of Locust Grove (“City”) is a municipal corporation duly organized and existing under the laws of the State of Georgia; and,

WHEREAS, the City sought competitive sealed bids from qualified contractors for furnishing professional consultant services necessary to complete a review and update of the City’s Impact Fee Program (“Project”); and,

WHEREAS, one bid was received on May 16, 2023 by the City for the Project; and,

WHEREAS, the sole responsive bidder is Ross Associates; and,

WHEREAS, Ross Associates appears to have the necessary financial and technical ability to complete the Project; and,

WHEREAS, the Mayor and Council have determined that the need for a review and update to the City’s Impact Fee Program is in the best interests of the City for the public good and general welfare, trade, commerce, industry and employment opportunities within the City and the state of Georgia,

THEREFORE, IT IS NOW RESOLVED BY THE CITY COUNCIL OF THE CITY OF LOCUST GROVE, GEORGIA, AS FOLLOWS:

1. **Acceptance of Bid.** The Mayor and the City Council, hereby makes contract bid award to Ross Associates in an amount not to exceed \$79,500. Scope of services and deliverables are enumerated in attached **Exhibit A**.
2. **Approval of Execution.** The Mayor, City Manager and Assistant City Manager are hereby authorized to execute all necessary documentation to effectuate this Resolution.

3. **Documents.** The City Clerk is authorized to execute, attest to, and seal any document which may be necessary to effectuate this Resolution, subject to approval as to form by the City Attorney and approval of contract by the Mayor and City Council.
4. **Compliance.** The Parties shall ensure that the contract and performance of same comply with House Bill 87 enacted in 2011 by the Georgia General Assembly.
5. **Severability.** To the extent any portion of this Resolution is declared to be invalid, unenforceable or non-binding, that shall not affect the remaining portions of this Resolution.
6. **Repeal of Conflicting Provisions.** All City Resolutions are hereby repealed to the extent they are inconsistent with this Resolution.
7. **Effective Date.** This Resolution shall take effect immediately.

THIS RESOLUTION adopted this 5th day of June , 2023.

Robert Price, Mayor

ATTEST:

APPROVED AS TO FORM:

Misty Spurling, City Clerk

City Attorney

(seal)

EXHIBIT A

**AN AGREEMENT BETWEEN
LOCUST GROVE, GEORGIA and ROSS ASSOCIATES
for
PROFESSIONAL SERVICES
RELATED TO THE UPDATE AND AMENDMENT OF
THE CITY'S IMPACT FEE PROGRAM**

THIS CONTRACT, entered into this _____ day of _____, 2023 (hereinafter referred to as the "effective date" of this Contract), by and between **LOCUST GROVE, GEORGIA** (hereinafter referred to as "the City"), a political subdivision of the State of Georgia, and **ROSS ASSOCIATES** (hereinafter referred to as "the Consultant"), a Sole Proprietor with offices at 340 N. Main Street, Madison, Georgia.

WITNESSETH THAT:

WHEREAS, the City has identified a need to study the City's Impact Fee Program and impact fees; and

WHEREAS, it is recognized that a Capital Improvements Element of the Comprehensive Plan is a crucial and necessary component of an impact fee program; and

WHEREAS, it is further recognized that an amendment of the City's Impact Fee Ordinance will be required to update and amend its impact fee program, consistent with the Georgia Development Impact Fee Act (O.C.G.A. § 36-71-1 *et seq.*); and

WHEREAS, the City desires to engage the services of an independent consultant to assist the City in its study and update of its Impact Fee Program and fees; and

WHEREAS, the Consultant has unique qualifications and experience applicable to the services required;

NOW, THEREFORE, in consideration of the mutual covenants contained herein, and for other good and valuable consideration, the City and the Consultant agree as follows:

SECTION 1. CONSULTANT'S SERVICES

1.1 Retention of Consultant

The City retains the Consultant and the Consultant accepts retention by the City to render the services defined and required in this Contract, and to perform such services in accordance

with the Scope of Services described herein and as may be amended or extended in writing by mutual agreement of the parties.

1.2 Scope of Services

The Scope of Services to be performed under this Contract is attached hereto as Attachment "A". Attachment "A" to this Contract contains substantive provisions of this Contract and the content, terms and conditions found in Attachment "A" are all hereby incorporated by reference and will be binding on both parties.

1.3 Time of Performance

This Contract will be effective upon execution by all parties for a term of 12 months from such Effective Date unless earlier terminated in accordance with the termination provisions of this Contract, or renewed or extended by the parties in writing as defined herein. Upon execution of the Contract, the City shall provide the Consultant with a written notice to proceed and the Consultant agrees to commence the work contemplated by this Contract within ten days of receipt of the City's notice to proceed. Upon such authorization to proceed, the Consultant shall commence such activities as required and appropriate under the Scope of Services and shall professionally and faithfully perform said duties and activities in the completion of the services with all due diligence and speed.

1.4 City Responsibilities

The City shall be responsible for administration related to public hearings and other meetings under this Contract including securing space for meetings, providing notice, and keeping minutes. The City shall supply to the Consultant such relevant plans, studies, data, and documents needed to perform the Scope of Services. The City shall supply to the Consultant such other records or information of relevance as may be needed and reasonably available for the completion of the Consultant's services hereunder and shall make available City personnel to meet with the Consultant at appropriate and mutually convenient times as needed to complete the work required under the Scope of Services.

1.5 City's Immunity

Nothing contained in this Contract shall be construed to be a waiver of the City's sovereign immunity or of any individual's qualified good faith immunity.

SECTION 2. COMPENSATION

2.1 Consultant's Fee

The total fee for all services that will be provided by the Consultant in accordance with the attached Scope of Services, which fee includes all out-of-pocket expenses for said services,

shall not exceed \$79,500.00. Compensation for Additional Services shall be computed in accordance with Section 2.3, below.

2.2 Payment of Consultant's Fee

The Consultant's fee shall be paid by the City based on monthly progress invoices by the Consultant. Monthly progress invoices shall be calculated on the basis of the work performed during the preceding month as a percentage of all work to be performed under the Scope of Services. Invoices will be due upon receipt by the City and payable within 30 calendar days, subject to approval that such work has been performed. Such approval shall not be unreasonably withheld or delayed.

2.3 Payment for Additional Services

Additional services may be performed by the Consultant upon the specific request of the City. Payment for such services shall be made on the basis of the hours expended for professional and travel time by the Consultant times the standard hourly rates of the individuals involved, as mutually agreeable to the City and the Consultant, plus the actual cost of expenses associated with said additional services. Standard hourly rates for the individuals to be involved will be submitted to the City in writing upon request for additional services but prior to commencement of any work under the request. As an alternative, the City and the Consultant can negotiate a lump sum amount to be paid for specific services, at the option of the City and as agreed to by the Consultant.

2.4 Renegotiations

If any action is taken or request made by the City that materially increases the cost to the Consultant of providing the services required under this Contract, the City and the Consultant agree to negotiate in good faith the amount of additional compensation that will be paid by the City as a result of said increase in cost. Services provided on an hourly basis as Additional Services may exceed the maximum amounts shown only upon the approval of the City.

2.5 City's Right of Inspection

At all reasonable times, for the purpose of review, the City shall have access to the pertinent offices, books, records, and costs incurred for services performed by the Consultant under this Contract.

SECTION 3. TERMINATION

3.1 Termination for Cause

If, through any course, the Consultant fails to fulfill its obligations under this Contract, or in the event that any material provisions or stipulations of this Contract are violated by the Consultant, the City shall thereupon have the right to terminate this Contract by serving written

notice to the Consultant of its intention to terminate the Contract, specifying the effective date of the termination and the reason(s) therefor. The effective date of termination shall be no less than fifteen days from the date of said notice. Upon receipt of said notice of termination, the Consultant shall have fifteen days preceding such effective date within which to cure any breach or default relating to this Contract. The failure to cure such breach or default shall entitle the City to terminate this Contract at the end of the time period without further notice. Following receipt of said notice of termination and failure to cure such breach or default, the Consultant shall deliver all work products completed as of the date of termination and shall be compensated by the City for those services accomplished and out-of-pocket expenses up to and including the effective date of termination.

3.2 Termination for Convenience

The City or the Consultant may terminate this Contract at any time for any reason by giving written notice thirty days in advance to the other party of the intention to terminate the Contract. Following receipt of said notice of termination, the Consultant shall be compensated by the City for those services accomplished and out-of-pocket expenses up to and including the date of receipt of said notice of termination and for such other services provided by mutual consent between the City and the Consultant from the date of receipt of the notice of termination to the effective date of said termination. All work products completed as of the date of notice of termination, and all work products completed between the date of receipt of the notice of termination to the effective date of said termination, shall be delivered to the City.

3.3 Dispute Resolution

Any dispute arising over the quality of the Consultant's work products, the amount of compensation due for services rendered, the extent to which the Consultant has fulfilled its obligations under this Contract, or the extent to which material provisions or stipulations of this Contract have been violated by the Consultant, shall be negotiated between the City and the Consultant in good faith. Issues that are not resolved through good faith negotiation shall be referred to mediation by a party mutually agreeable to the City and the Consultant. Issues that are not resolved through mediation shall be referred to the Superior Court of Camden City, Georgia, for determination by that Court.

SECTION 4. MISCELLANEOUS PROVISIONS

4.1 Independent Contractor

Nothing contained herein shall be deemed to create a relationship other than that of independent contractor between the City and the Consultant. Under no circumstances shall the Consultant, its principals, employees, associates, subcontractors, successors, or assigns be deemed employees, agents, partners, successors, assigns, or legal representatives of the City except as specifically required herein.

4.2 Retention of Subconsultants

The Consultant may retain through subcontract other firms or individuals as appropriate and necessary to fully execute the services included in this Contract. Regardless of the retention of any subconsultant, the Consultant shall act as Project Manager and shall be fully responsible for the completion of all services in a timely and acceptable manner. Such subconsultant shall be subject to the same provisions as contained in this Contract between the Consultant and the City. It is contemplated that the Consultant will engage the services of Paige Hatley, President of Hatley Plans, LLC, as a subconsultant to work on portions of this project under the Consultant's direction.

4.3 Assignment

Neither party shall assign this Contract without the prior express written consent of the other party. Any attempted assignment by the Consultant without the prior express written approval of the City shall at the City's sole option terminate this Contract without any notice to the Contractor of such termination. The City and the Consultant each bind itself, its successors, assigns, and legal representatives in respect to all covenants, agreements, and obligations contained herein.

4.4 Conflict of Interest

The Consultant represents and warrants that it presently has no interest, direct or indirect, and covenants and agrees that it will not, during the term of this Contract, acquire any interest, direct or indirect, that would conflict in any manner or degree with the performance of its duties and obligations hereunder.

4.5 Notice

All notices or other communications required to be given between the parties under this Contract shall be in writing and shall have been duly given when delivered personally in hand, or upon delivery by mail or other carrier or delivery service, to the persons and at the addresses below. Said persons, their successors or assigns, shall be the official representatives of the parties hereto:

a. City:

Mr. Tim Young, City Manager
City of Locust Grove
3644 Hwy 42
Locust Grove, Georgia 30248

b. Consultant:

Mr. William F. Ross, President
Ross Associates

340 N. Main Street
Madison, Georgia 30650

4.6 Consultant's Representation

William F. Ross is sole proprietor of Ross Associates (Consultant), and as such, is authorized to bind and enter into contracts on behalf of the Consultant.

4.7 Entire Agreement

This Contract, along with any attachments incorporated herein by reference, constitutes the entire agreement of the parties pertaining to the subject matter hereof and is intended as a complete and exclusive statement of the promises, representations, negotiations, discussions, and agreements oral or otherwise that have been made in connection therewith. No modification or amendment to this Contract shall be binding upon the parties unless it is in writing and executed by the duly authorized representatives of the City and the Consultant.

4.8 Force Majeure

Neither the City nor the Consultant shall be deemed in violation of this Contract if either is prevented from performing its obligations hereunder for any reason beyond its control.

4.9 Governing Law

This Contract and the rights and obligations of the parties hereto shall be governed by and construed according to the laws of the State of Georgia.

4.10 Waiver of Breach

The waiver by either party of a breach or violation of any provision of this Contract shall not operate or be construed to be a waiver of any subsequent breach or violation of the same or other provision thereof.

4.11 Severability

If any provision of this Contract is held to be unenforceable for any reason, the unenforceability thereof shall not affect the remainder of the Contract, which shall remain in full force and effect and be enforceable in accordance with its terms.

4.12 Paragraph Headings

The paragraph headings used in this Contract are for the convenience of the parties. The paragraph headings are not intended to define, limit, or describe the scope or intent of this Contract and are to be given no legal effect.

IN WITNESS HEREOF, the parties hereto have set their hands and seals, effective upon the "effective date" first written above.

ROSS ASSOCIATES



(Signature)
Mr. William F. Ross, President

LOCUST GROVE, GEORGIA

Attest:

(Signature)

(Title)

(Signature)

(Title)

(Date)

Attachment A: Scope of Services

Scope of Services

Our services will include advice and assistance to the City in general on impact fee matters, the preparation of an Impact Fee Methodology Report (including all impact fee calculations), a completely amended Capital Improvements Element, the preparation of a revised fee schedule, and a review of the Impact Fee Ordinance as to state law requirements and City requirements.

The results of our proposed services will be the completion of an updated impact fee program and fee schedule for the City meeting all legal and administrative requirements. In addition, the amended CIE will conform to DCA requirements for inclusion in the City's Comprehensive Plan.

Our assistance will include the following items:

Task 1: Project Initiation

- a. Review of and revisions to unfinished public facilities projects carried over from the current impact fee program, if any, with specific attention to possible changes to such projects (including any applicable updates to the projects' estimated costs) in any or all of the City's three public facility categories:
 - Police Protection,
 - Parks and Recreation facilities, and
 - Road Improvements.
- b. Project cost estimates and start dates for impact fee eligible projects, determined in conjunction with City departmental estimates.

Budgeted capital projects, adopted Capital Improvement Plan project listings and departmental service plans/projections will be key inputs for the impact fee eligible project listing. All current cost estimates will be converted to Net Present Value (NPV) using average annual inflation rates (the CPI and Engineering News Record's BCI and CCI for building and other construction projects), discounted by the City's current investment interest rate.

Deliverables:

- Kick-off meeting with all affected departments regarding planned projects.

Task 2: Impact Fee Methodology Report

The preparation of a completely new Impact Fee Methodology Report addressing the City's three impact fee eligible public facility categories listed above, including new impact fee calculations, which will reflect the following:

Forecasts

- a. Population, dwelling unit and employment forecasts to 2050.

Depending on the type and quality of data available, this step may include preparation of trend analyses against historic annual population data for various trial time frames, prepared as 1st, 2nd and 3rd order regressions; a comparative analysis with ARC projections; and/or a "percentage-share" calculation based on Woods & Poole forecasts. Household and dwelling unit estimates will be based on available Census data, as will employment forecasts. The results will be presented in a Technical Appendix containing all pertinent calculations.

- b. Traffic generation.

Current and future traffic volumes generated by city residents and businesses will be calculated to determine new growth's share of road improvement costs. The calculations will be presented in a Technical Appendix to be attached to the Methodology Report.

- c. Tax digest or SPLOST revenue forecasts.

These will be needed to calculate credits for new development taxes attributable to impact fee projects, and will reflect average new house sales prices and per-employee non-residential property values or new growth's share of future SPLOST collections, as applicable. The calculation of a credit against impact fees is needed to avoid potential situations of double taxation.

- d. Inflation factors.

Inflation factors to be used in Net Present Value calculations of future expenditures will be established, including the Engineering News Record's Atlanta area Building Construction Index for new buildings, ENR's Construction Index for other construction projects such as recreation facilities, and the CPI for non-construction items such as vehicles and recreation facilities.

Level of Service (LOS) Standards.

- a. Current level of service.

- Current LOS will be calculated for police protection services based on the floor area of existing facilities and existing number of eligible vehicles serving the current day-night population. The existing LOS for parks & recreation will be based on the land area in City

parks and the number of recreation facilities, floor area or other pertinent measurement. For roads, trip generation calculations will determine the current LOS.

b. Future level of service.

- For all public facility categories, we will take into consideration planned improvements already approved or proposed, and extension of the current LOS to serve the future day-night population or dwelling units, as applicable.

c. Determination of the LOS standards to use.

The current, future or other LOS standards recommended will be a function of City policies and the most advantageous impact fee calculations themselves.

Funding Mechanisms

Funding from the General Fund and from other sources (such as TSPLOST, bonds or short-term financing vehicles) will be considered to the extent that credits will have to be given to new growth to avoid double taxation issues.

Maximum Impact Fees

The maximum potential impact fee for each land use category is calculated to set the ceiling on fees that can be charged under the state law. The actual fees to be charged will be decided by the City Council as part of the Impact Fee Ordinance review/revision process.

Deliverables:

- Partial Draft of the Methodology Report focused on population, housing, employment and traffic projections; cost inflation factors; and introductory chapters.
- Methodology Report containing all forecasts, credit data and NPV components, impact fee calculations for each public facility category, a maximum fee schedule by land use category for each public facility category, a summary regarding the financial implications of the impact fee program, and comparisons between the current fees allowed and the maximum new fee calculations. Pertinent Technical Appendices will be attached.
- Attendance at one City Council work session to review the proposed Methodology Report, which then will be finalized reflecting City Council comments.

Task 3: Capital Improvements Element

- a. A new (amended) Capital Improvements Element (CIE) based on the finalized Methodology Report will be prepared. The CIE document will be drawn from those portions of the Methodology Report (with supplemental text added) that are required to be included by the Georgia Department of Community Affairs.

- b. Impact fee projects will be summarized in the CIE, and included in a Community Work Program format that will serve as an amendment to the full CWP in the Comprehensive Plan.

Deliverables:

- Amended Capital Improvements Element containing all data required by the Georgia Department of Community Affairs. Pertinent Technical Appendices will be included.
- PowerPoint presentation summarizing the Capital Improvements Element for public and City Council presentation.
- Attendance at the transmittal public hearing before the City Council regarding transmittal of the updated CIE to the Atlanta Regional Commission and DCA.
- Review of comments from DCA on the new CIE (if any) and appropriate responses.

Task 4: Adoption of the Updated Impact Fee Program

Adoption will involve the following:

- a. Ordinance Review.

Preparation of a review of the City's Impact Fee Ordinance and recommendations (if any) to assure conformance to the Georgia Development Impact Fee Law, as most recently amended, and issues raised by City staff.

- b. City Council Briefing.

Preparation of briefing materials as needed for discussions with the City Council members regarding appropriate levels of impact fees to be charged.

- c. Fee Schedule for Adoption.

Preparation of a new impact fee schedule as an amendment to the City's Impact Fee Ordinance.

Deliverables:

- Attendance at one City Council workshop or individual briefings to discuss the draft Impact Fee Ordinance and fee schedule.
- Attendance at one meeting of the City Council to adopt the amended CIE, Impact Fee Ordinance revisions if needed, and the new impact fee schedule.
- Delivery of the final adopted version of the CIE, to be forwarded to ARC by City staff.

Task 5: Continuing Services

Following adoption and implementation of the updated Impact Fee Program, ROSS+associates will stand ready to answer questions, provide explanations and otherwise provide continuing advice to the City as questions or issues arise for a period of one year at no cost to the City. This assistance will be advisory in nature and delivered by telephone or email as appropriate to the inquiry.



Administration Department

P. O. Box 900
Locust Grove, Georgia 30248

Phone: (770) 957-5043
Facsimile: (866) 364-0996

Item Coversheet

Item: Ordinance to amend the FY 23 Operating and Capital Improvements Budget for the 1st Quarter of 2023

Action Item: Yes No

Public Hearing Item: Yes No

Executive Session Item: Yes No

Advertised Date: N/A

Budget Item: Yes, General Funds, Funds 275, 350, 505, 540

Date Received: May 11, 2023 (update)

Workshop Date: May 15, 2023 (Discussion – City Manager)

Regular Meeting Date: June 5, 2023 - Action

Discussion:

Attached is the final ordinance for amendment in the First Quarter for the FY 23 Budget. Initially there are minor tweaks regarding additional revenue projections based on the final collections of FY 22 not originally anticipated. Further are some tweaks related to expenditure amounts related some to disaster expenditures that will be finally wrapped up in the mid-year budget adjustment process.

Recommendation:

APPROVE Ordinance to amend the Locust Grove Operating and Capital Improvements Budget for the first quarter of the 2023 Fiscal Year.

ORDINANCE NO. _____

TO REVISE THE OPERATING AND CAPITAL IMPROVEMENTS BUDGET OF THE CITY OF LOCUST GROVE FOR THE FIRST QUARTER OF THE 2023 FISCAL YEAR PURSUANT TO SECTIONS 6.35 AND 6.36 OF THE CITY CHARTER; TO PROVIDE FOR ADDITIONAL UNAPPROPRIATED FUNDS FOR CERTAIN OPERATING EXPENDITURES; TO AUTHORIZE THE CITY MANAGER AND CITY CLERK TO CARRY OUT ALL NECESSARY PROCEDURES TO MAKE ALL AMENDMENTS TO THE BUDGET AND OPERATE FINANCIAL OPERATIONS IN ACCORDANCE WITH THE CODE OF ORDINANCES OF THE CITY OF LOCUST GROVE; TO PROVIDE SEVERABILITY; TO REPEAL CONFLICTING ORDINANCES; TO PROVIDE AN EFFECTIVE DATE; AND FOR OTHER PURPOSES

THE COUNCIL OF THE CITY OF LOCUST GROVE HEREBY ORDAINS

SECTION 1. Amendment of Appropriations of the Fiscal Year 2023 General Funds Budget, Hotel/Motel Fund, SPLOST, T-SPLOST, Water and Sewer Fund Budget, Sanitation Fund, and Stormwater Fund Budget. That certain General Fund appropriation accounts are **INCREASED** a net of **\$219,735.00**; that certain Confiscated Asset Fund appropriation accounts are **INCREASED** a net of **\$15,000.00**; that certain HOTEL/MOTEL Fund appropriation accounts are **INCREASED** a net of **\$165,000.00**; that certain Development Impact Fee Fund appropriation accounts are **DECREASED** a net of **\$48,125.00**; that certain Water and Sewer Fund appropriation accounts are **DECREASED** a net of **\$370,000.00**; **AND** that certain Sanitation Fund appropriation accounts are **INCREASED** a net of **\$24,000.00** as shown in **Exhibit “A”**.

SECTION 2. Amendment of the Fiscal Year 2023 Budget and Capital Improvements Budget. Pursuant to Section 6.35 and 6.36 of the City Charter, the Mayor and Council hereby amends the Operating and Capital Improvements Budget of the City of Locust Grove, Georgia for the 2023 Fiscal Year, which begins January 1, 2023 and ends on December 31, 2023 as attached hereto and incorporated herein at **Exhibit “A”**.

SECTION 3. Statement of Legal Level of Control. That the “legal level of control” as defined in O.C.G.A. 36-81-3 is set at the departmental level, meaning that the City Manager in his capacity as Budget Officer is authorized to move appropriations from one line item to another within a department, but under no circumstances may expenditures or expenses exceed the amount appropriated for a department without a further Budget amendment approved by the Mayor and City Council.

SECTION 4. Statement of Lapse on All Appropriations. That all appropriations shall lapse at the end of the fiscal year.

SECTION 5. Authorization to City Manager and City Clerk. The City Manager as Budget Officer and City Clerk are hereby authorized to install the necessary Budget Amendments and carry out all necessary procedures to close out the prior year and operate financial operations of the City in accordance with the Code of Ordinances of the City of Locust Grove.

SECTION 6. Severability.

A. It is hereby declared to be the intention of the City Council that all sections, paragraphs, sentences, clauses and phrases of this Ordinance are and were, upon their enactment, believed by the City Council to be fully valid, enforceable and constitutional.

B. It is hereby declared to be the intention of the City Council that, to the greatest extent allowed by law, each and every section, paragraph, sentence, clause or phrase of this Ordinance is severable from every other Section, paragraph, sentence, clause or phrase of this Ordinance. It is hereby further declared to be the intention of the City Council that, to the greatest extent allowed by law, no section, paragraph, sentence, clause or phrase of this Ordinance is mutually dependent upon any other Section, paragraph, sentence, clause or phrase of this Ordinance.

C. In the event that any section, paragraph, sentence, clause or phrase of this Ordinance shall, for any reason whatsoever, be declared invalid, unconstitutional or otherwise unenforceable by the valid judgment or decree of any court of competent jurisdiction, it is the express intent of the City Council that such invalidity, unconstitutionality or unenforceability shall, to the greatest extent allowed by law, not render invalid, unconstitutional or otherwise unenforceable any of the remaining sections, paragraphs, sentences, clauses, or phrases of the Ordinance and that, to the greatest extent allowed by law, all remaining Sections, paragraphs, sentences, clauses, or phrases of the Ordinance shall remain valid, constitutional, enforceable, and of full force and effect.

SECTION 7. Repeal of Conflicting Provision. Except as otherwise provided herein, all ordinances or parts of ordinances in conflict with this ordinance are hereby repealed.

SECTION 8. Effective Date. This ordinance shall become effective immediately upon its adoption by the Mayor and Council of the City of Locust Grove.

SO ORDAINED this 5th day of June, 2023

ROBERT PRICE, Mayor

ATTEST:

APPROVED AS TO FORM:

MISTY SPURLING, City Clerk
(Seal)

CITY ATTORNEY

EXHIBIT “A”

**AMENDED FINAL OPERATING AND CAPITAL IMPROVEMENTS BUDGET
FOR THE CITY OF LOCUST GROVE, GEORGIA
FOR THE FISCAL YEAR 2023 – Thru 1st Quarter (33%)**

General Fund (100) FY 2023 Proposed		Original 23	YTD	25% of FY	Amend	Rev FY 23
TAXES						
3-0000-31.1100	REAL PROPERTY - CURRENT YEAR	-	-	0.0%		0
3-0000-31.1200	REAL PROPERTY - PRIOR YEAR	-	-	0.0%		0
3-0000-31.1220	GENERAL BUS LIC INSURANCE	-	-	0.0%		0
3-0000-31.1315	MOTOR VEHICLE TAVT TAX	25,000	22,225.8	88.9%	317000	342,000
3-0000-31.1316	ALTERNATIVE AAVT TAX	-	-	0.0%	20,000	20,000
3-0000-31.1340	INTANGIBLE TAX	80,000	5,599.5	7.0%		80,000
3-0000-31.1350	RAILROAD EQUIPMENT TAX	1,750	-	0.0%		
3-0000-31.1400	PERSONAL PROPERTY - PRIOR YEAR	-	-	0.0%		0
3-0000-31.1600	REAL ESTATE TRANSFERS	25,500	8,877.6	34.8%		25,500
3-0000-31.1710	FRANCHISE TAX - ELECTRIC	445,000	555,256.3	124.8%	100000	545,000
3-0000-31.1711	CAPITAL CREDIT REFUND	-	-	0.0%		0
3-0000-31.1730	FRANCHISE TAX - NATURAL GAS	37,500	-	0.0%		37,500
3-0000-31.1750	FRANCHISE TAX - CABLE TV	120,000	24,581.5	20.5%		120,000
3-0000-31.1751	FRANCHISE TAX - VIDEO SVC	-	1,939.1	0.0%		0
3-0000-31.1760	FRANCHISE TAX - TELEPHONE	10,000	1,243.9	12.4%		10,000
3-0000-31.1790	OTHER FRANCHISE TAX	-	18,987.1	0.0%		0
3-0000-31.3100	LOCAL OPTION SALES /USE TAX	2,877,000	583,893.7	20.3%		2,877,000
3-0000-31.3150	TAVT + AAVT	210,000	-	0.0%		210,000
3-0000-31.4201	ALCOHOL TAX	445,000	89,987.9	20.2%		445,000
3-0000-31.4250	DISTILLED SPIRITS ALCOHOL EXCI	-	-	0.0%		0
3-0000-31.4300	MIXED DRINK EXCISE TAX	-	-	0.0%		0
3-0000-31.6100	OCCUPATION TAXES	320,000	162,754.8	50.9%		320,000
3-0000-31.6120	REGULATORY FEES	-	8,225.0	0.0%		0
3-0000-31.6200	INSURANCE PREMIUM TAX	500,000	-	0.0%	415,000	915,000
3-0000-31.6300	FINANCIAL INSTITUTION TAXES	-	-	0.0%		0
3-0000-31.9000	PENALTIES/INTEREST DEL TAXES	-	-	0.0%		0
TOTAL TAXES		5,096,750	1,483,572	29.1%	852,000	5,948,750
LICENSES AND PERMITS						
3-0000-32.1110	ALCOHOL BEV-BEER LICENSE	17500	0	0.0%		17,500
3-0000-32.1120	ALCOHOL BEV WINE LICENSE	12500	0	0.0%		12,500
3-0000-32.1130	ALCOHOL BEV - LIQUOR LICENSE	40500	0	0.0%		40,500
3-0000-32.1135	LIQUOR/DISTILLD SPIRITS RETAIL	0	0	0.0%		0
3-0000-32.1200	GENERAL BUSINESS LICENSE	0	0	0.0%		0
3-0000-32.1210	REAL ESTATE BUSINESS LICENSE	0	0	0.0%		0

General Fund (100) FY 2023 Proposed		Original 23	YTD	25% of FY	Amend	Rev FY 23
3-0000-32.1220	GENERAL BUS LIC - INSURANCE	22500	14100	62.7%		22,500
3-0000-32.1900	REGULATORY FEES	35000	800	2.3%		35,000
3-0000-32.2120	BLDG PERMITS /INSPECTIONS - RES	350000	59540.28	17.0%		350,000
3-0000-32.2130	BLDG PERMIT/INSPECTIONS - COMM	500000	92878.27	18.6%		500,000
3-0000-32.3100	BUSINESS LICENSE PENALTY	0	0	0.0%		0
3-0000-32.3300	SHORT-TERM VACA RENTAL REG FEE	0	0	0.0%		0
TOTAL LICENSES AND PERMITS		978,000	167,319	17.1%	0	978,000
INTERGOVERNMENTAL REV						
3-0000-33.4450	GRANT BULLET PROOF VEST	500	0	0.0%		500
3-0000-33.4500	GRANT / DONATIONS -COPS	250	1950	780.0%	1750	2,000
3-0000-33.5000	DONATION-PLAYGROUND EQUIP	0	0	0.0%		0
3-0000-33.6100	DONATIONS	0	650	0.0%	1000	1,000
3-0000-33.7000	CDBG GRANT	0	0	0.0%		0
3-0000-34.1301	DISPOSITION OF PROPERTY	0	0	0.0%		0
TOTAL INTERGOVERNMENTAL REV		750	2,600	346.7%	2,750	3,500
CHARGES FOR SERVICES						
3-0000-34.1310	ZONING INSPECTION FEES	35000	5429.3	15.5%		35,000
3-0000-34.1311	LAND DEVELOPMENT FEES	90000	9551.2	10.6%		90,000
3-0000-34.1312	SITE PLAN REVIEW FEES	45000	7600	16.9%		45,000
3-0000-34.1321	SOIL EROSION FEES	5000	0	0.0%		5,000
3-0000-34.1323	STREET LIGHT DISTRICT REV.	20000	0	0.0%		20,000
3-0000-34.1325	TREE REPLACEMENT REVENUE	0	0	0.0%		0
3-0000-34.1900	SIDEWALKS	0	0	0.0%		0
3-0000-34.1910	QUALIFYING FEE FOR ELECTION	1000	0	0.0%		1,000
3-0000-34.1950	ACCIDENT REPORTS	7500	1865	24.9%		7,500
3-0000-34.1955	CRIMINAL HISTORY REPORTS	0	0	0.0%		0
3-0000-34.1960	ADM CHARGE ON FINES	12500	0	0.0%		12,500
3-0000-34.1990	ADM CHARGE FOR INCODE	15000	0	0.0%		15,000
3-0000-34.6100	BACKGROUND CHECK FEES	2000	0	0.0%		2,000
3-0000-34.9001	DONATIONS	0	0	0.0%		0
3-0000-34.9300	BAD CHECK FEES	100	0	0.0%		100
TOTAL CHARGES FOR SERVICES		233,100	24,446	10.5%	0	233,100
FINES AND FORFEITURES						

General Fund (100) FY 2023 Proposed		Original 23	YTD	25% of FY	Amend	Rev FY 23
3-0000-35.1170	FINES & FORFEITURES	120000	24581.52	20.5%		120,000
3-0000-35.1175	BOND ACCOUNT	0	1939.08	0.0%		0
TOTAL FINES AND FORFEITURES		120,000	26,521	22.1%	0	120,000
INVESTMENT INCOME				0.0%		
				0.0%		
3-0000-36.1000	INTEREST REVENUES	15000	10352.65	69.0%	25000	40,000
TOTAL INVESTMENT INCOME		15,000	10,353	69.0%	25,000	40,000
MISCELLANEOUS REVENUE				0.0%		
				0.0%		
3-0000-38.1000	RENTS & ROYALTIES	500	0	0.0%		500
3-0000-38.1010	SPECIAL EVENT PERMIT	500	0	0.0%		500
3-0000-38.1025	PAVILLION RENTAL	500	0	0.0%		500
3-0000-38.1050	HOUSE RENTAL - LOCUST ROAD	25000	4846.1	19.4%		25,000
3-0000-38.3000	INS REIMBURSE DAMAGE PROPERTY	25000	4150	16.6%		25,000
3-0000-38.3100	INS REIMBURSE WKS COMP	500	0	0.0%		500
3-0000-38.3400	INS REIMBURSE FOR OVERPAYMENT	500	0	0.0%		500
3-0000-38.5000	LMIG PROGRAM	450000	0	0.0%		450,000
3-0000-38.6007	INTERGOVERNMENTAL SDS AGREEMEN	0	0	0.0%		0
3-0000-38.9000	MISCELLANEOUS REVENUE	15000	401.23	2.7%		15,000
3-0000-38.9010	RETURN CHECK FEES	100	0	0.0%		100
3-0000-38.9100	REFUNDS POLICE DEPT	0	0	0.0%		0
3-0000-38.9200	REFUNDS PUBLIC WORKS	0	0	0.0%		0
3-0000-38.9300	REFUNDS ADMINISTRATIONS	7500	0	0.0%		7,500
3-0000-38.9900	PRIOR YEAR REVENUE	732885	0	0.0%	-304150	428,735
3-0000-38.9910	RESERVE - TRANSPORTATION	0	0	0.0%		0
TOTAL MISCELLANEOUS REVENUE		1,257,985	9,397	0.7%	-304,150	953,835
OTHER FINANCIAL SOURCES				0.0%		
				0.0%		
3-0000-39.1000	TRANSFER IN - HOTEL MOTEL	0	0	0.0%		0
3-0000-39.1100	OPERATING TRANSFERS	0	0	0.0%		0
3-0000-39.1210	ADMIN FEE - WATER TRANSFER IN	255000	0	0.0%	195000	450,000
3-0000-39.1220	ADMIN FEE - SEWER TRANSFER IN	530000	0	0.0%	-75000	455,000
3-0000-39.1230	ADMIN FEE - SANIT TRANSFER IN	10000	0	0.0%		10,000
3-0000-39.1240	ADMIN FEE - STORM TRANSFER IN	62000	0	0.0%	-22000	40,000
3-0000-39.1250	ADMIN FEE - H/M TRANSFER IN	105000	0	0.0%		105,000
3-0000-88.8888	DEBT PROCEEDS	0	0	0.0%		0

General Fund (100) FY 2023 Proposed						
	Original 23	YTD	25% of FY	Amend	Rev FY 23	
TOTAL OTHER FINANCIAL SOURCES	962,000	0	0.0%		955,000	
TOTAL NON DEPARTMENTAL	8,663,585	1,724,207	19.9%	673,600	9,232,185	
TOTAL REVENUES	8,663,585	1,724,207	19.9%	673,600	9,232,185	
Department 1110 - Elected Officials						
PERSONAL SVC & EMP BEN						
5-1110-51.1150	10800	2700	25.0%		10,800	
5-1110-51.1155	50400	12600	25.0%		50,400	
5-1110-51.2200	1000	221.85	22.2%		1,000	
5-1110-51.2400	30000	8419.32	28.1%		30,000	
5-1110-51.2750	500	69.38	13.9%		500	
TOTAL PERSONAL SVC & EMP BEN	92,700	24,011	25.9%		92,700	
PURCHASED/CONTRACTED SVC			0.0%			
5-1110-52.1200	1,000	-	-		1,000	
5-1110-52.1230	2,500	-	-		2,500	
5-1110-52.1301	15,000	3,676	0		15,000	
5-1110-52.1302	2,000	-	-		2,000	
5-1110-52.3100	17,500	-	-		17,500	
5-1110-52.3200	500	46	0		500	
5-1110-52.3220	500	-	-		500	
5-1110-52.3310	1,000	-	-		1,000	
5-1110-52.3500	4,000	195	0		4,000	
5-1110-52.3600	500	348	1		500	
5-1110-52.3700	-	-	-		-	
5-1110-52.3701	4,500	-	-		4,500	
5-1110-52.3702	3,750	-	-		3,750	
5-1110-52.3703	3,750	416	0		3,750	
5-1110-52.3707	3,750	571	0		3,750	
5-1110-52.3709	3,750	517	0		3,750	
5-1110-52.3710	-	-	-		-	
5-1110-52.3711	3,750	-	-		3,750	
5-1110-52.3712	3,750	438	0		3,750	
5-1110-52.3720	-	-	-	2,500	2,500	
5-1110-52.3750	33,500	1,210	0		33,500	

General Fund (100) FY 2023 Proposed						
	Original 23	YTD	25% of FY	Amend	Rev FY 23	
TOTAL PURCHASED/CONTRACTED SV	105,000	7,418	7.1%	2,500	107,500	
SUPPLIES						
5-1110-53.1105	500	-	-		500	
5-1110-53.1785	1,000	-	-		1,000	
TOTAL SUPPLIES	1500	0	0.0%	0	1,500	
CAPITAL OUTLAY						
5-1110-54.2450	1,500	-	-		1,500	
TOTAL CAPITAL OUTLAY	1,500	0	0.0%		1,500	
TOTAL ELECTED OFFICIALS	200,700	31,428	15.7%	2,500	203,200	
Administration (100-1510)						
PERSONAL SVC & EMP BEN						
5-1510-51.1100	767,750	188,803	24.6%	38,500	806,250	
5-1510-51.1300	2,000	300	15.0%		2,000	
5-1510-51.2100	92,500	30,979	33.5%		92,500	
5-1510-51.2200	9,000	2,696	30.0%		9,000	
5-1510-51.2400	55,000	17,170	31.2%		55,000	
5-1510-51.2700	32,500	22,331	68.7%	(7,500)	25,000	
5-1510-51.2750	2,000	-	0.0%		2,000	
TOTAL PERSONAL SVC & EMP BEN	960,750	262,280	27.3%	31,000	991,750	
PURCHASED/CONTRACTED SVC						
5-1510-52.1200	10,000	5	0.1%	15,000	25,000	
5-1510-52.1220	35,000	14,865	42.5%	30,000	65,000	
5-1510-52.1230	60,000	18,407	30.7%		60,000	
5-1510-52.1301	110,000	67,742	61.6%	25,000	135,000	
5-1510-52.1302	25,000	560	2.2%		25,000	
5-1510-52.1400	500	55	11.0%		500	
5-1510-52.2210	7,500	1,181	15.7%		7,500	
5-1510-52.2211	5,000	1,725	34.5%		5,000	
5-1510-52.2212	3,000	750	25.0%		3,000	
5-1510-52.2240	50,000	3,557	7.1%		50,000	
5-1510-52.2245	12,500	-	0.0%		12,500	

General Fund (100) FY 2023 Proposed		Original 23	YTD	25% of FY	Amend	Rev FY 23
5-1510-52.2250	OTHER EQUIP. REPAIRS/MAINT	12,000	2,576	21.5%		12,000
5-1510-52.2320	RENTAL OF EQUIPMENT & VEHICLE	5,000	-	0.0%		5,000
5-1510-52.3100	RISK MANAGEMENT INSURANCE	30,000	-	0.0%		30,000
5-1510-52.3200	COMMUNICATIONS-CELL PHONES	2,000	726	36.3%		2,000
5-1510-52.3205	INTERNET	-	-	0.0%		-
5-1510-52.3220	NETWORK/TELEPHONE	80,000	17,367	21.7%		80,000
5-1510-52.3300	ADVERTISING	2,000	-	0.0%		2,000
5-1510-52.3310	PUBLIC NOTICES	2,500	1,008	40.3%		2,500
5-1510-52.3500	TRAVEL MILEAGE REIMBURSEMENT	2,500	316	12.6%		2,500
5-1510-52.3600	DUES & FEES	6,500	3,557	54.7%		6,500
5-1510-52.3700	EDUCATION & TRAINING	15,000	1,649	11.0%		15,000
5-1510-52.3750	MEETINGS & CONFERENCE	8,000	921	11.5%		8,000
5-1510-52.3851	CONTRACTED SVCS - CITY HALL	20,000	5,238	26.2%		20,000
5-1510-52.3855	CONTRACTS & SPONSORSHIPS	10,000	588	5.9%		10,000
5-1510-52.3970	POSTAGE	25,000	6,573	26.3%		25,000
TOTAL PURCHASED/CONTRACTED SVC		539,000	149,365	27.7%	70,000	609,000
SUPPLIES						
5-1510-53.1105	OFFICE SUPPLIES	10,000	1,777	17.8%		10,000
5-1510-53.1107	BANK & CREDIT CARD CHARGES	25,000	750	3.0%		25,000
5-1510-53.1108	CHECK FRAUD PROVISION	-	-	0.0%		-
5-1510-53.1160	OPERATING EQUIPMENT	1,000	-	0.0%		1,000
5-1510-53.1161	GIFTS & FLOWERS	4,000	73	1.8%		4,000
5-1510-53.1164	COVID-19 SUPPLIES	-	-	0.0%		-
5-1510-53.1165	DISASTER RELIEF SUPPLIES	500	-	0.0%		500
5-1510-53.1205	UTILITIES	50,000	12,231	24.5%		50,000
5-1510-53.1210	STORMWATER FEES	1,500	-	0.0%		1,500
5-1510-53.1700	OTHER SUPPLIES	7,000	873	12.5%		7,000
5-1510-53.1728	MAYORS MOTORCADE	1,200	-	0.0%		1,200
5-1510-53.1729	CITY EVENTS	10,000	-	0.0%		10,000
5-1510-53.1785	UNIFORMS	2,500	150	6.0%		2,500
5-1510-53.1790	ELECTION EXPENSE	5,000	32,536	650.7%	30,000	35,000
5-1510-53.1795	MISCELLANEOUS	-	-	0.0%		-
TOTAL SUPPLIES		117,700	48,390	41.1%	30,000	147,700
CAPITAL OUTLAY						

General Fund (100) FY 2023 Proposed		Original 23	YTD	25% of FY	Amend	Rev FY 23
5-1510-54.1100	ACQUISITION OF PROPERTY	150,000	-	0.0%	(25,000)	125,000
5-1510-54.1310	RENOVATIONS TO CITY HALL	150,000	-	0.0%	(25,000)	125,000
5-1510-54.2200	VEHICLES	-	-	0.0%	-	-
5-1510-54.2300	FURNITURE & FIXTURES	20,000	-	0.0%	-	20,000
5-1510-54.2400	COMPUTERS	25,000	-	0.0%	-	25,000
5-1510-54.2450	COMP HARDWARE/SERVER CAPITAL	40,000	130,746	326.9%	110,000	150,000
5-1510-54.2500	EQUIPMENT	5,000	2,975	59.5%	-	5,000
TOTAL CAPITAL OUTLAY		420,000	133,721	31.8%	60,000	480,000
DEPRECIATION & AMORT				0.0%		
5-1510-56.1000	DEPRECIATION	-	-	0.0%	-	-
TOTAL DEPRECIATION & AMORT		0	0	0.0%	0	0
PAYMENT TO OTHERS				0.0%		
5-1510-57.9000	CONTINGENCIES	17,500	-	0.0%	-	17,500
TOTAL PAYMENT TO OTHERS		20,000	0	0.0%	-	20,000
TOTAL ADMINISTRATION		2,054,950	593,756	28.9%	191,000	2,245,950
Municipal Court (100-2650)						
PERSONAL SVC & EMP BEN						
5-2650-51.1100	REGULAR EMPLOYEES	105,000	26,447	25.2%	5,500	110,500
5-2650-51.1158	JUDGE SALARY	25,000	5,500	22.0%	-	25,000
5-2650-51.1300	OVERTIME	500	198	39.6%	-	500
5-2650-51.2100	GROUP INSURANCE	13,500	4,313	31.9%	-	13,500
5-2650-51.2200	FICA (SOCIAL SECURITY)	1,500	381	25.4%	-	1,500
5-2650-51.2400	RETIREMENT	11,000	3,097	28.2%	-	11,000
5-2650-51.2500	TUITION REIMBURSEMENTS	-	-	0.0%	-	-
5-2650-51.2700	WORKER'S COMPENSATION	3,500	2,627	75.1%	-	3,500
5-2650-51.2750	UNEMPLOYMENT TAX - GEORGIA	250	9	3.5%	-	250
TOTAL PERSONAL SVC & EMP BEN		160,250	42,572	26.6%	5,500	165,750
PURCHASED/CONTRACTED SVC						
5-2650-52.1230	LEGAL	4,000	-	0.0%	-	4,000
5-2650-52.1260	SOLICITOR	22,000	4,443	20.2%	-	22,000
5-2650-52.1261	PUBLIC DEFENDER	15,000	3,600	24.0%	-	15,000

General Fund (100) FY 2023 Proposed		Original 23	YTD	25% of FY	Amend	Rev FY 23
5-2650-52.1301	TECHNICAL - SOFTWARE	15,000	10,528	70.2%	5,000	20,000
5-2650-52.1302	TECHNICAL - HARDWARE	2,500	-	0.0%		2,500
5-2650-52.1400	DRUG & MEDICAL	200	-	0.0%		200
5-2650-52.2210	AUTO / TRUCK EXPENSE	-	-	0.0%		-
5-2650-52.2211	AUTO / TRUCK FUEL	-	-	0.0%		-
5-2650-52.2250	OTHER EQUIP. REPAIRS/MAINT	-	-	0.0%		-
5-2650-52.3100	RISK MANAGEMENT INSURANCE	5,000	-	0.0%		5,000
5-2650-52.3200	COMMUNICATIONS-CELL PHONES	500	46	9.3%		500
5-2650-52.3205	INTERNET	1,000	-	0.0%		1,000
5-2650-52.3310	PUBLIC NOTICES	100	-	0.0%		100
5-2650-52.3500	TRAVEL-MILEAGE REIMBURSEMENT	400	-	0.0%		400
5-2650-52.3600	DUES & FEES	400	148	37.1%		400
5-2650-52.3700	EDUCATION & TRAINING	3,500	200	5.7%		3,500
5-2650-52.3970	POSTAGE	1,000	-	0.0%		1,000
5-2650-52.3995	COURT COST-SUBPEONAS	200	-	0.0%		200
TOTAL PURCHASED/CONTRACTED SVC		70,800	18,966	26.8%	5,000	75,800
SUPPLIES						
5-2650-53.1105	OFFICE SUPPLIES	2,500	632	25.3%		2,500
5-2650-53.1107	BANK & CREDIT CARD CHARGES	20,000	-	0.0%	(2,000)	18,000
5-2650-53.1160	OPERATING EQUIPMENT	100	274	274.3%	400	500
5-2650-53.1700	OTHER SUPPLIES	1,000	33	3.3%		1,000
5-2650-53.1785	UNIFORMS	600	-	0.0%		600
5-2650-53.1786	BOOT ALLOWANCE	-	-	0.0%		-
5-2650-53.1795	MISCELLANEOUS	-	-	0.0%		-
TOTAL SUPPLIES		24,200	939	3.9%	-1,600	22,600
CAPITAL OUTLAY						
5-2650-54.2200	VEHICLES	-	-	0.0%		-
5-2650-54.2300	FURNITURE & FIXTURES	-	-	0.0%		-
5-2650-54.2400	COMPUTERS	1,500	-	0.0%		1,500
5-2650-54.2420	PAPERLESS COURT SYSTEM	7,500	-	0.0%		7,500
5-2650-54.2450	COMP HARDWARE/COURTWARE	5,000	-	0.0%		5,000
5-2650-54.2500	EQUIPMENT COMMUNITY SERV	250	-	0.0%		250
5-2650-54.2550	EQUIPMENT - COURT	1,000	-	0.0%		1,000
TOTAL CAPITAL OUTLAY		15,250	0	0.0%	0	15,250

General Fund (100) FY 2023 Proposed		Original 23	YTD	25% of FY	Amend	Rev FY 23
DEPRECIATION & AMORT				0.0%		
5-2650-56.1000	DEPRECIATION	-	-	0.0%		0
TOTAL DEPRECIATION & AMORT		-	-	0.0%	-	0
PAYMENT TO OTHERS				0.0%		
5-2650-57.2000	JAIL CONSTRUCTION	32,000	5,749	18.0%	-750	31,250
5-2650-57.2100	GEORGIA CRIME VICTIMS	1,000	-	0.0%		1,000
5-2650-57.2110	VICTIMS ASSISTANCE FUND	15,500	2,665	17.2%		15,500
5-2650-57.2120	POLICE OFFICERS A & B FUND	35	8,339	23826.8%	30965	31,000
5-2650-57.2130	POLICE /PROSCUTOR TRAINING	30,000	5,224	17.4%	-1000	29,000
5-2650-57.2150	SPINAL INJURY TRUST FUND	2,000	158	7.9%		2,000
5-2650-57.2160	GBI CRIME LAB	750	-	0.0%		750
5-2650-57.2170	INDIGENT DEFENSE -POTFIOF	35,000	5,636	16.1%	-2500	32,500
5-2650-57.2180	DRUG TREATMENT & EDUCATION	6,500	-	0.0%		6,500
5-2650-57.2190	DRIVERS ED & TRAINING FUND	5,000	33	0.7%		5,000
5-2650-57.9000	CONTINGENCIES	5,000	-	0.0%		5,000
TOTAL PAYMENT TO OTHERS		132,785	27,804	20.9%	26,715	159,500
TOTAL MUNICIPAL COURT		332,485	71,315	21.4%	30,615	363,100
Police (100 - 3230)				0.0%		
PERSONAL SVC & EMP BEN				0.0%		
5-3230-51.1100	REGULAR EMPLOYEES	1,975,000	480,990	24.4%	92500	2,067,500
5-3230-51.1300	OVERTIME	40,000	24,818	62.0%	20000	60,000
5-3230-51.2100	GROUP INSURANCE	340,000	111,762	32.9%		340,000
5-3230-51.2200	FICA (SOCIAL SECURITY)	23,000	6,717	29.2%		23,000
5-3230-51.2400	RETIREMENT	120,000	40,225	33.5%		120,000
5-3230-51.2500	TUITION REIMBURSEMENTS	-	-	0.0%		0
5-3230-51.2700	WORKER'S COMPENSATION	48,000	39,408	82.1%	-2500	45,500
5-3230-51.2750	UNEMPLOYMENT TAX - GEORGIA	3,500	91	2.6%		3,500
TOTAL PERSONAL SVC & EMP BEN		2,549,500	704,012	27.6%	110,000	2,659,500
PURCHASED/CONTRACTED SVC				0.0%		
5-3230-52.1230	LEGAL	5,000	110	2.2%		5,000
5-3230-52.1301	TECHNICAL - SOFTWARE	70,000	25,351	36.2%		70,000

General Fund (100) FY 2023 Proposed		Original 23	YTD	25% of FY	Amend	Rev FY 23
5-3230-52.1302	TECHNICAL - HARDWARE	80,000	28,831	36.0%		80,000
5-3230-52.1400	DRUG & MEDICAL	2,000	355	17.8%		2,000
5-3230-52.2210	AUTO/TRUCK EXPENSES	20,000	16,458	82.3%	10000	30,000
5-3230-52.2211	AUTO GAS & FUEL	70,000	7,896	11.3%		70,000
5-3230-52.2240	BUILDING & GROUNDS	27,500	5,262	19.1%		27,500
5-3230-52.2250	OTHER EQUIP. REPAIRS/MAINT	3,500	1,978	56.5%		3,500
5-3230-52.3100	RISK MANAGEMENT INSURANCE	45,000	-	0.0%		45,000
5-3230-52.3200	COMMUNICATIONS-CELL PHONES	27,500	7,057	25.7%		27,500
5-3230-52.3201	TELEPHONE	-	-	0.0%		0
5-3230-52.3205	INTERNET	-	-	0.0%		0
5-3230-52.3220	NETWORK/TELEPHONE	15,000	3,600	24.0%		15,000
5-3230-52.3300	ADVERTISING	1,500	-	0.0%		1,500
5-3230-52.3500	TRAVEL MILEAGE REIMBURSEMENT	1,000	-	0.0%		1,000
5-3230-52.3600	DUES & FEES	3,000	2,113	70.4%		3,000
5-3230-52.3700	EDUCATION & TRAINING	6,500	3,166	48.7%		6,500
5-3230-52.3750	MEETINGS & CONFERENCE	12,000	1,541	12.8%		12,000
5-3230-52.3850	CONTRACT LABOR	-	-	0.0%		0
5-3230-52.3851	CONTRACTED SVCS - PSB	25,000	3,422	13.7%		25,000
5-3230-52.3950	TASK FORCE EXPENSES	-	-	0.0%		0
5-3230-52.3970	POSTAGE	2,000	28	1.4%		2,000
5-3230-52.3980	INVESTIGATIONS	-	-	0.0%		0
TOTAL PURCHASED/CONTRACTED SVC		416,500	107,167	25.7%	10,000	426,500
SUPPLIES						
5-3230-53.1105	OFFICE SUPPLIES	3,500	1,000	28.6%		3,500
5-3230-53.1107	BANK & CREDIT CARD CHARGES	25,000	-	0.0%	-2500	22,500
5-3230-53.1150	OPERATING SUPPLIES	4,500	673	15.0%		4,500
5-3230-53.1160	OPERATING EQUIPMENT	15,000	9,397	62.6%	10000	25,000
5-3230-53.1170	COPS EXPENSE	5,000	-	0.0%		5,000
5-3230-53.1205	UTILITIES	32,500	3,449	10.6%	-2500	30,000
5-3230-53.1210	STORMWATER FEES	1,000	-	0.0%		1,000
5-3230-53.1700	OTHER SUPPLIES	4,000	993	24.8%		4,000
5-3230-53.1785	UNIFORMS	26,000	4,839	18.6%		26,000
5-3230-53.1795	MISCELLANEOUS	-	-	0.0%		0
TOTAL SUPPLIES		116,500	20,351	17.5%	5,000	121,500
CAPITAL OUTLAY						

General Fund (100) FY 2023 Proposed		Original 23	YTD	25% of FY	Amend	Rev FY 23
5-3230-54.1310	PUBLIC SAFETY BUILDING	15,000	-	0.0%	-10000	5,000
5-3230-54.2200	VEHICLES	140,000	152,552	109.0%	15000	155,000
5-3230-54.2300	FURNITURE & FIXTURES	7,000	-	0.0%	-2000	5,000
5-3230-54.2400	COMPUTERS	10,000	7,224	72.2%		10,000
5-3230-54.2450	COMP HARDWARE/SERVER CAPITAL	10,000	-	0.0%		10,000
5-3230-54.2500	EQUIPMENT	127,500	-	0.0%	-10000	117,500
	TOTAL CAPITAL OUTLAY	309,500	159,776	51.6%	-7,000	302,500
	INTERFUND CHARGES					
5-3230-55.2300	JUDGEMENTS	7,500	-	0.0%	-1500	6,000
	TOTAL INTERFUND CHARGES	7,500	0	0.0%	-1,500	6,000
	DEPRECIATION & AMORT					
5-3230-56.1000	DEPRECIATION	-	-	0.0%		0
	TOTAL DEPRECIATION & AMORT	-	-	0.0%	-	0
	PAYMENT TO OTHERS					
5-3230-57.9000	CONTINGENCIES	12,500	-	0.0%	-1,500	11,000
	TOTAL PAYMENT TO OTHERS	12,500	0	0.0%	-1,500	11,000
	DEBT SERVICE					
5-3230-58.1204	PD INCODE SOFTWARE PRINCIPAL	-	-	0.0%		0
5-3230-58.1205	LEASE BUILDING FOR SQUAD RM	-	-	0.0%		0
5-3230-58.2204	PD INCODE SOFTWARE INTEREST	-	-	0.0%		0
	TOTAL DEBT SERVICE	0	0	0.0%	0	0
	TOTAL POLICE DEPARTMENT	3,412,000	991,306	29.1%	115,000	3,527,000
	Street Maintenance (100 - 4210)			0.0%		
	PERSONAL SVC & EMP BEN			0.0%		
5-4210-51.1100	REGULAR EMPLOYEES	600,000	141,436	23.6%	100,000	700,000
5-4210-51.1200	SEASONAL EMPLOYEES	3,000	-	0.0%	-3,000	0
5-4210-51.1300	OVERTIME	10,000	4,565	45.6%	5,500	15,500
5-4210-51.2100	GROUP INSURANCE	139,000	38,184	27.5%		139,000
5-4210-51.2200	FICA (SOCIAL SECURITY)	7,500	2,071	27.6%		7,500

General Fund (100) FY 2023 Proposed		Original 23	YTD	25% of FY	Amend	Rev FY 23
5-4210-51.2400	RETIREMENT	60,000	16,034	26.7%		60,000
5-4210-51.2700	WORKER'S COMPENSATION	29,500	15,763	53.4%	-8,500	21,000
5-4210-51.2750	UNEMPLOYMENT TAX - GEORGIA	2,500	4	0.2%		2,500
TOTAL PERSONAL SVC & EMP BEN PURCHASED/CONTRACTED SVC		851,500	218,058	25.6%	94,000	945,500
5-4210-52.1200	PROFESSIONAL	1,000	-	0.0%		1,000
5-4210-52.1230	LEGAL	500	-	0.0%		500
5-4210-52.1250	ENGINEERING	25,000	-	0.0%		25,000
5-4210-52.1301	TECHNICAL - SOFTWARE	30,000	1,695	5.6%	-7,500	22,500
5-4210-52.1302	TECHNICAL - HARDWARE	2,500	-	0.0%	-500	2,000
5-4210-52.1400	DRUG & MEDICAL	1,500	901	60.1%		1,500
5-4210-52.2210	AUTO/TRUCK EXPENSES	10,000	7,126	71.3%	5,000	15,000
5-4210-52.2211	AUTO GAS & FUEL	27,500	2,932	10.7%	-2,500	25,000
5-4210-52.2240	BUILDING & GROUNDS	10,000	3,078	30.8%		10,000
5-4210-52.2250	OTHER EQUIP. REPAIRS/MAINT	15,000	2,325	15.5%		15,000
5-4210-52.2260	STREET MAINTENANCE & PAVING	50,000	4,228	8.5%		50,000
5-4210-52.2320	RENTAL OF EQUIPMENT & VEHICLE	17,500	697	4.0%		17,500
5-4210-52.3100	RISK MANAGEMENT INSURANCE	31,500	-	0.0%		31,500
5-4210-52.3200	COMMUNICATIONS-CELL PHONES	7,000	1,918	27.4%	1,500	8,500
5-4210-52.3201	TELEPHONE	-	-	0.0%		0
5-4210-52.3205	INTERNET	5,000	-	0.0%	-1,000	4,000
5-4210-52.3310	PUBLIC NOTICES	200	-	0.0%		200
5-4210-52.3600	DUES & FEES	2,500	835	33.4%		2,500
5-4210-52.3700	EDUCATION & TRAINING	2,000	-	0.0%		2,000
5-4210-52.3750	MEETINGS & CONFERENCE	750	205	27.3%		750
5-4210-52.3940	TREE MAINTENANCE	30,000	17,313	57.7%	5,000	35,000
TOTAL PURCHASED/CONTRACTED SVC SUPPLIES		269,450	43,251	16.1%	0	269,450
5-4210-53.1105	OFFICE SUPPLIES	1,500	118	7.9%		1,500
5-4210-53.1150	OPERATING SUPPLIES	15,000	945	6.3%	-2,500	12,500
5-4210-53.1160	OPERATING EQUIPMENT	8,000	5,777	72.2%	2,500	10,500
5-4210-53.1205	UTILITIES	35,500	878	2.5%	-2,500	33,000
5-4210-53.1210	STORMWATER FEES	2,000	-	0.0%		2,000
5-4210-53.1225	STREET LIGHTS	117,500	19,041	16.2%		117,500

General Fund (100) FY 2023 Proposed		Original 23	YTD	25% of FY	Amend	Rev FY 23
5-4210-53.1230	STREET LIGHT DISTRICT SVCS	25,000	7,267	29.1%		25,000
5-4210-53.1700	OTHER SUPPLIES	3,000	549	18.3%		3,000
5-4210-53.1720	CHRISTMAS DECORATIONS	5,000	3,482	69.6%		5,000
5-4210-53.1725	SIGNALS STRT SIGNS MARKINGS	30,000	3,855	12.9%		30,000
5-4210-53.1775	REPAIR DAMAGE PROPERTY	10,000	4,000	40.0%		10,000
5-4210-53.1785	UNIFORMS	15,000	3,666	24.4%		15,000
5-4210-53.1786	BOOT ALLOWANCE	1,000	-	0.0%		1,000
5-4210-53.1795	MISCELLANEOUS	-	-	0.0%		0
TOTAL SUPPLIES		268,500	49,577	18.5%	-2,500	266,000
CAPITAL OUTLAY				0.0%		
5-4210-54.1401	BILL GRDNR PKWY/SR 42 IMPROVE	-	-	0.0%		0
5-4210-54.1405	STATE LMIG PAVING	-	-	0.0%		0
5-4210-54.1406	HENRY CO. HWY MAINT.	-	-	0.0%		0
5-4210-54.1407	SIGNALS & INTERSECTIONS	-	-	0.0%		0
5-4210-54.2200	VEHICLES	50,000	-	0.0%		50,000
5-4210-54.2300	FURNITURE & FIXTURES	1,500	-	0.0%		1,500
5-4210-54.2400	COMPUTER	-	-	0.0%		0
5-4210-54.2450	COMP HARDWARE/SERVER CAPITAL	5,000	-	0.0%		5,000
5-4210-54.2500	EQUIPMENT	55,000	4,508	8.2%		55,000
5-4210-54.2700	SECURITY SYSTEM	-	-	0.0%		0
TOTAL CAPITAL OUTLAY		111,500	4,508	4.0%	0	111,500
DEPRECIATION & AMORT				0.0%		
5-4210-56.1000	DEPRECIATION	-	-	0.0%		0
TOTAL DEPRECIATION & AMORT		0	0	0.0%		0
PAYMENT TO OTHERS				0.0%		
5-4210-57.3100	CLAIMS	-	-	0.0%		0
5-4210-57.9000	CONTINGENCIES	5,000	-	0.0%		5,000
TOTAL PAYMENT TO OTHERS		5,000	0	0.0%		5,000
TOTAL STREET DEPARTMENT		1,505,950	315,394	20.9%	91,500	1,597,450
Fleet Maintenance (100 -4220)				0.0%		
PERSONAL SVC & EMP BEN				0.0%		

General Fund (100) FY 2023 Proposed		Original 23	YTD	25% of FY	Amend	Rev FY 23
		44,500	11,973	0.0%		
5-4220-51.1100	REGULAR EMPLOYEES			26.9%	2,000	46,500
5-4220-51.1300	OVERTIME	1,000	353	35.3%		1,000
5-4220-51.2100	GROUP INSURANCE	3,000	4	0.1%		3,000
5-4220-51.2200	FICA (SOCIAL SECURITY)	500	179	35.7%		500
5-4220-51.2400	RETIREMENT	1,000	1,203	120.3%	2,000	3,000
5-4220-51.2500	TUITION REIMBURSEMENTS	-	-	0.0%		0
5-4220-51.2700	WORKER'S COMPENSATION	2,000	1,313	65.7%		2,000
5-4220-51.2750	UNEMPLOYMENT TAX - GEORGIA	250	-	0.0%		250
TOTAL PERSONAL SVC & EMP BEN		52,250	15,024	28.8%	4,000	56,250
PURCHASED/CONTRACTED SVC				0.0%		
				0.0%		
5-4220-52.1400	DRUG & MEDICAL	125	-	0.0%		125
5-4220-52.2210	AUTO/TRUCK EXPENSES	2,000	-	0.0%	-250	1,750
5-4220-52.2211	AUTO GAS & FUEL	1,000	-	0.0%	-250	750
5-4220-52.2240	BUILDING & GROUNDS	5,000	1,029	20.6%		5,000
5-4220-52.2250	OTHER EQUIP. REPAIRS/MAINT	3,500	-	0.0%	-500	3,000
5-4220-52.3100	RISK MANAGEMENT INSURANCE	2,500	-	0.0%		2,500
5-4220-52.3200	COMMUNICATIONS-CELL PHONES	250	-	0.0%		250
5-4220-52.3205	INTERNET	-	-	0.0%		0
5-4220-52.3600	DUES & FEES	200	50	24.8%		200
5-4220-52.3700	EDUCATION & TRAINING	1,000	-	0.0%		1,000
5-4220-52.3851	REPAIR SERVICES	45,000	-	0.0%	-15,000	30,000
TOTAL PURCHASED/CONTRACTED SVC		60,575	1,078	1.8%	-16,000	44,575
SUPPLIES				0.0%		
				0.0%		
5-4220-53.1150	OPERATING SUPPLIES	7,500	3,797	50.6%	2,500	10,000
5-4220-53.1160	OPERATING EQUIPMENT	5,000	640	12.8%		5,000
5-4220-53.1205	UTILITIES	2,500	-	0.0%	-500	2,000
5-4220-53.1700	OTHER SUPPLIES	1,500	407	27.1%		1,500
5-4220-53.1785	UNIFORMS	400	-	0.0%		400
5-4220-53.1786	BOOT ALLOWANCE	120	-	0.0%		120
5-4220-53.1795	MISCELLANEOUS	-	-	0.0%		0
5-4220-53.2320	RENTAL OF EQUIPMENT & VEHICLE	500	-	0.0%		500
TOTAL SUPPLIES		17,520	4,844	27.6%	2,000	19,520
CAPITAL OUTLAY				0.0%		

General Fund (100) FY 2023 Proposed		Original 23	YTD	25% of FY	Amend	Rev FY 23
				0.0%		
5-4220-54.2100	MACHINERY	1,000	-	0.0%		1,000
5-4220-54.2200	VEHICLES	-	-	0.0%		0
5-4220-54.2300	FURNITURE & FIXTURES	1,000	-	0.0%		1,000
5-4220-54.2400	COMPUTER	-	-	0.0%		0
5-4220-54.2450	COMP HARDWARE/SERVER CAPITAL	500	-	0.0%		500
5-4220-54.2500	EQUIPMENT	500	-	0.0%		500
	TOTAL CAPITAL OUTLAY	3,000	0	0.0%	0	3,000
	DEPRECIATION & AMORT			0.0%		
				0.0%		
5-4220-56.1000	DEPRECIATION	-	-	0.0%		0
	TOTAL DEPRECIATION & AMORT	0	0	0.0%	0	0
	PAYMENT TO OTHERS			0.0%		
				0.0%		
5-4220-57.9000	CONTINGENCIES	1,000	-	0.0%	-250	750
	TOTAL PAYMENT TO OTHERS	1,000	0	0.0%	-250	750
	TOTAL FLEET MAINTENANCE	133,345	20,947	15.7%	-10,000	123,345
	Parks and Recreation (100 -6220)					
	PERSONAL SVC & EMP BEN					
5-6220-51.1100	REGULAR EMPLOYEES	30,000	-	0.0%	-5,000	25,000
5-6220-51.1300	OVERTIME	500	-	0.0%		500
5-6220-51.2100	GROUP INSURANCE	2,500	-	0.0%	-500	2,000
5-6220-51.2200	FICA (SOCIAL SECURITY)	200	-	0.0%		200
5-6220-51.2400	RETIREMENT	500	-	0.0%		500
5-6220-51.2500	TUITION REIMBURSEMENTS	-	-	0.0%		0
5-6220-51.2700	WORKER'S COMPENSATION	500	-	0.0%		500
5-6220-51.2750	UNEMPLOYMENT TAX - GEORGIA	200	-	0.0%		200
	TOTAL PERSONAL SVC & EMP BEN	34,400	0	0.0%	-5,500	28,900
	PURCHASED/CONTRACTED SVC					
5-6220-52.2240	BUILDING & GROUNDS	20,000	1,309	6.5%	-1,500	18,500
5-6220-52.3100	RISK MANAGEMENT INSURANCE	1,000	-	0.0%		1,000
5-6220-52.3220	NETWORK/TELEPHONE	-	720	0.0%	1,500	1,500
	TOTAL PURCHASED/CONTRACTED SVC	21,000	2,029	9.7%	0	21,000

General Fund (100) FY 2023 Proposed		Original 23	YTD	25% of FY	Amend	Rev FY 23
SUPPLIES						
	UTILITIES	25,000	5,963	23.9%		25,000
5-6220-53.1205						
	STORMWATER FEES	5,000	-	0.0%		5,000
5-6220-53.1210						
	OPERATING SUPPLIES	2,500	-	0.0%		2,500
5-6220-53.1600						
	OTHER SUPPLIES	2,000	64	3.2%		2,000
5-6220-53.1700						
	TOTAL SUPPLIES	34,500	6,027	17.5%	0	34,500
	CAPITAL OUTLAY					
	REPAIRS & MAINTENANCE	1,000	-	0.0%		1,000
5-6220-54.1100						
	TANGER PARK	2,500	-	0.0%		2,500
5-6220-54.1101						
	BUILDINGS	2,500	-	0.0%		2,500
5-6220-54.1300						
	TOTAL CAPITAL OUTLAY	6,000	0	0.0%	0	6,000
	TOTAL PARKS & RECREATION	95,900	8,056	8.4%	-5,500	90,400
Community Development (7220)						
PERSONAL SVC & EMP BEN						
	REGULAR EMPLOYEES	510,000	128,176	25.1%	27,000	537,000
5-7220-51.1100						
	OVERTIME	1,000	-	0.0%	-250	750
5-7220-51.1300						
	GROUP INSURANCE	57,500	20,875	36.3%	5,000	62,500
5-7220-51.2100						
	FICA (SOCIAL SECURITY)	6,000	1,798	30.0%		6,000
5-7220-51.2200						
	RETIREMENT	30,000	9,276	30.9%		30,000
5-7220-51.2400						
	WORKER'S COMPENSATION	12,500	9,195	73.6%	-2,500	10,000
5-7220-51.2700						
	UNEMPLOYMENT TAX - GEORGIA	1,000	-	0.0%		1,000
5-7220-51.2750						
	TOTAL PERSONAL SVC & EMP BEN	618,000	169,321	27.4%	29,250	647,250
	PURCHASED/CONTRACTED SVC					
	PROFESSIONAL	55,000	43	0.1%	-5,000	50,000
5-7220-52.1200						
	LEGAL	5,000	1,162	23.2%		5,000
5-7220-52.1230						
	ENGINEERING	20,000	-	0.0%	-2,500	17,500
5-7220-52.1250						
	TECHNICAL - SOFTWARE	45,000	52,847	117.4%	35,000	80,000
5-7220-52.1301						
	TECHNICAL - HARDWARE	7,500	-	0.0%	-2,500	5,000
5-7220-52.1302						
	DRUG & MEDICAL	250	-	0.0%		250
5-7220-52.1400						
	AUTO/TRUCK EXPENSES	2,000	-	0.0%	-500	1,500
5-7220-52.2210						
	AUTO GAS & FUEL	7,500	581	7.7%	-1,500	6,000
5-7220-52.2211						

General Fund (100) FY 2023 Proposed		Original 23	YTD	25% of FY	Amend	Rev FY 23
5-7220-52.2250	OTHER EQUIP. REPAIRS/MAINT	7,000	1,858	26.5%		7,000
5-7220-52.3100	RISK MANAGEMENT INSURANCE	10,000	-	0.0%		10,000
5-7220-52.3200	COMMUNICATIONS-CELL PHONES	3,500	893	25.5%		3,500
5-7220-52.3201	TELEPHONE	500	-	0.0%		500
5-7220-52.3205	INTERNET	1,500	-	0.0%		1,500
5-7220-52.3310	PUBLIC NOTICES	4,000	187	4.7%		4,000
5-7220-52.3600	DUES & FEES	1,500	399	26.6%		1,500
5-7220-52.3700	EDUCATION & TRAINING	7,500	279	3.7%		7,500
5-7220-52.3850	CONTRACT LABOR	275,000	76,780	27.9%		275,000
5-7220-52.3900	ABATEMENT	12,500	-	0.0%		12,500
5-7220-52.3970	POSTAGE	1,000	-	0.0%		1,000
TOTAL PURCHASED/CONTRACTED SVC		466,250	135,029	29.0%	23,000	489,250
SUPPLIES						
5-7220-53.1105	OFFICE SUPPLIES	7,500	447	6.0%	-1,000	6,500
5-7220-53.1107	BANK & CREDIT CARD CHARGES	18,500	677	3.7%	-2,500	16,000
5-7220-53.1160	OPERATING EQUIPMENT	1,000	-	0.0%		1,000
5-7220-53.1700	OTHER SUPPLIES	-	-	0.0%		0
5-7220-53.1785	UNIFORMS	3,000	633	21.1%		3,000
5-7220-53.1786	BOOT ALLOWANCE	240	-	0.0%		240
5-7220-53.1795	MISCELLANEOUS	-	-	0.0%		0
TOTAL SUPPLIES		30,240	1,757	5.8%	-3,500	26,740
CAPITAL OUTLAY						
5-7220-54.2200	VEHICLES	-	-	0.0%		0
5-7220-54.2300	FURNITURE & FIXTURES	5,000	-	0.0%		5,000
5-7220-54.2400	COMPUTERS	5,000	-	0.0%		5,000
5-7220-54.2450	COMPUTER MAINTENANCE	20,000	-	0.0%	-15,000	5,000
5-7220-54.2500	EQUIPMENT	1,500	6,182	412.1%	5,500	7,000
TOTAL CAPITAL OUTLAY		31,500	6,182	19.6%	-9,500	22,000
DEPRECIATION & AMORT						
5-7220-56.1000	DEPRECIATION	-	-	0.0%	0	0
TOTAL DEPRECIATION & AMORT		0	0	0.0%	0	0
PAYMENT TO OTHERS						
				0.0%		

General Fund (100) FY 2023 Proposed		Original 23	YTD	25% of FY	Amend	Rev FY 23
5-7220-57.9000	CONTINGENCIES	2,000	-	0.0%	-500	1,500
	TOTAL PAYMENT TO OTHERS	2,000	0	0.0%	-500	1,500
	TOTAL COMMUNITY DEVELOPMENT	1,147,990	312,288	27.2%	38,750	1,186,740
	TOTAL EXPENDITURES	8,883,320	2,344,490	26.4%	453,865	9,337,185
	REVENUE OVER/(UNDER) EXPENDITURES	-219,735	-620,283	282.3%	219,735	0

Confiscated Assets Fund 210						
		FY23	YTD	Percent	Adjust.	Rev FY 23
Confiscated Assets Fund 210				-		
FINES AND FORFEITURES				-		
				-		
3-0000-35.1300	CONF. ASSETS -RESTRICTED	5,000	12,219	244%	8,000	13,000
3-0000-35.1301	EVIDENCE REV.- UNRESTRICTED	13,000	16,788	129%	7,000	20,000
TOTAL FINES AND FORFEITURES		18,000	29,007	161%	15,000	33,000
MISCELLANEOUS REVENUE				-		
				-		
3-0000-36.1000	INTEREST INCOME	0	0	0%		-
3-0000-38.3000	INSURANCE REIMBURSE DAMAGE PRO	0	0	0%		-
3-0000-38.9010	MISCELLANEOUS	0	0	0%		-
3-0000-38.9050	PRIOR YEAR REVENUE	15,000	0	0%		15,000
3-0000-39.1000	TRANSFER IN-GENERAL FUND	0	0	0%		-
TOTAL MISCELLANEOUS REVENUE		15,000	-	-	-	15,000
TOTAL NON DEPARTMENTAL		33,000	29,007	88%	15,000	48,000
TOTAL REVENUES		33,000	29,007	88%	15,000	48,000
PURCHASED/CONTRACTED SVC				-		
				-		
5-3230-52.2210	AUTO/TRUCK EXP	0	0	0%		-
5-3230-52.3300	ADVERTISING	0	0	0%		-
TOTAL PURCHASED/CONTRACTED SVC		-	-	-		-
CAPITAL OUTLAY				-		
				-		
5-3230-54.2200	POLICE DEPARTMENT VEHICLES	0	0	0%	35,000	35,000
5-3230-54.2500	EQUIPMENT/FURNISHING	0	0	0%		-
5-3230-54.2520	CRIME SCENE EQUIP.	0	0	0%		-
5-3230-54.2530	EQUIPMENT FOR CARS	22,000	0	0%	(10,000)	12,000
5-3230-54.2540	EQUIPMENT FOR OFFICERS	11,000	0	0%	(10,000)	1,000
TOTAL CAPITAL OUTLAY		33,000	-	-	15,000	48,000
PAYMENT TO OTHERS				-		
				-		
5-3230-57.3100	PYMT TO DA OFFICE	0	0	0%		-
TOTAL PAYMENT TO OTHERS		-	-	-		-
TOTAL POLICE DEPARTMENT		33,000	-	-	15,000	48,000
TOTAL EXPENDITURES		33,000	-	-	15,000	48,000
REVENUE OVER/(UNDER) EXPENDITURES		-	29,007	-	-	-

Hotel/Motel - Main Street - DDA Fund 275		FY 22	YTD	70% FY22	Year 23	FY 23 Budget
Hotel/Motel - Main Street - DDA Fund 275						
TAXES						
3-0000-31.4100	HOTEL / MOTEL TAX	1,085,000	288,303	26.6%	165,000	1,250,000
TOTAL TAXES		1,085,000	288,303	26.6%	165,000	1,250,000
INVESTMENT INCOME						
3-0000-36.1000	INTEREST INCOME	100	12	12.2%		100
TOTAL INVESTMENT INCOME		100	12	12.2%	0	100
MISCELLANEOUS REVENUE						
3-0000-38.9050	PRIOR YEAR REVENUE	0	0	0.0%		0
3-0000-38.9060	LCI GRANT - ARC	0	0	0.0%		0
3-0000-38.9062	MISCELLANEOUS GRANTS	0	0	0.0%		0
3-0000-38.9080	MISC DONATIONS	100	0	0.0%		100
3-0000-38.9090	MISC INCOME	0	0	0.0%		0
3-7560-34.9300	RTN CHECK FEES	0	0	0.0%		0
3-7560-38.9030	DDA DONATIONS	0	0	0.0%		0
TOTAL MISCELLANEOUS REVENUE		100	0	0.0%	0	100
TOTAL NON DEPARTMENTAL		1,085,200	288,315	26.6%	165,000	1,250,200
TOTAL REVENUES		1,085,200	288,315	26.6%	165,000	1,250,200
PURCHASED/CONTRACTED SVC						
5-0000-52.1210	ADMIN FEE - H/M TRANSFER OUT	105,000	0	0.0%		105,000
Dept 7520						
5-7520-52.1200	PROFESSIONAL SVCS	0	0	0.0%		0
5-7520-52.3250	I-75 LIGHTING	0	0	0.0%		0
5-7520-52.3300	ADVERTISING	0	480	0.0%		0
	Total 7520	0	480	0.0%		0
Dept 7540 TOURISM - (strikethrough reassign to 7550)						
5-7540-51.1100	REGULAR EMPLOYEES	0		0.0%		0
5-7540-51.2100	GROUP INSURANCE	0		0.0%		0
5-7540-51.2200	FICA (SOCIAL SECURITY)	0		0.0%		0
5-7540-51.2400	RETIREMENT	0		0.0%		0
5-7540-51.2700	WORKER'S COMPENSATION	0		0.0%		0

Hotel/Motel - Main Street - DDA Fund 275		FY 22	YTD	70% FY22	Year 23	FY 23 Budget
5-7540-51.2750	UNEMPLOYMENT TAX - GEORGIA	0		0.0%		0
5-7540-52.1230	LEGAL			0.0%		0
5-7540-52.1400	DRUG & MEDICAL			0.0%		0
5-7540-52.2250	OTHER EQUIP. REPAIRS/MAINT			0.0%		0
5-7540-52.2320	RENTAL EQUIPMENT			0.0%		0
5-7540-52.3100	RISK MANAGEMENT	0		0.0%		0
5-7540-52.3200	COMMUNICATIONS-CELL PHONE	0		0.0%		0
5-7540-52.3205	INTERNET	0		0.0%		0
5-7540-52.3250	I-75 LIGHTING	10,000	0	0.0%		10,000
5-7540-52.3300	ADVERTISING			0.0%		0
5-7540-52.3310	PUBLIC NOTICES	0		0.0%		0
5-7540-52.3500	TRAVEL-MILE REIMBURSEMENT	0		0.0%		0
5-7540-52.3600	DUES & FEES	0		0.0%		0
5-7540-52.3700	EDUCATION & TRAINING	0		0.0%		0
5-7540-52.3750	MEETINGS & CONFERENCE	0		0.0%		0
5-7540-52.3855	EVENT ENTERTAINMENT-CONTRACTS	0		0.0%		0
5-7540-52.3970	POSTAGE	0		0.0%		0
5-7540-53.1105	OFFICE SUPPLIES	0		0.0%		0
5-7540-53.1107	BANK & CREDIT CARD CHARGES	0		0.0%		0
5-7540-53.1160	OPERATING EQUIPMENT	0		0.0%		0
5-7540-53.1700	OTHER SUPPLIES	0		0.0%		0
5-7540-53.1720	CHRISTMAS DECORATIONS	0		0.0%		0
5-7540-53.1729	GHY/EVENTS	0		0.0%		0
5-7540-53.1750	PROMOTIONS	0		0.0%		0
5-7540-53.1785	UNIFORMS	0		0.0%		0
5-7540-54.2300	FURNITURE & FIXTURES	0		0.0%		0
5-7540-54.2400	COMPUTERS	0		0.0%		0
5-7540-54.2450	COMPUTER MAINTENANCE	0		0.0%		0
5-7540-54.2500	EQUIPMENT	0		0.0%		0
5-7540-57.3200	PYMT TO CVB			0.0%		0
TOTAL PURCHASED/CONTRACTED SVC		10,000	0	0.0%	0	10,000
PURCHASED/CONTRACTED SVC - Tourism (7540)						
5-7550-52.1200	PROFESSIONAL SVCS	10,000	0	0.0%		10,000
5-7550-52.3300	ADVERTISING	15,000	3,439	22.9%		15,000
5-7540-52.3850	CONTRACTED SERVICES	0	12,672	0.0%		0

Hotel/Motel - Main Street - DDA Fund 275		FY 22	YTD	70% FY22	Year 23	FY 23 Budget
TOTAL PURCHASED/CONTRACTED SVC		25,000	16,111	64.4%	0	25,000
PAYMENT TO OTHERS						
5-7540-57.3200	PYMT TO CVB *	315,000	126,133	40.0%	95,000	410,000
TOTAL PAYMENT TO OTHERS		315,000	126,133	40.0%	95,000	410,000
Total Tourism		340,000	142,244	41.8%	95,000	435,000
PERSONAL SVC & EMP BENEFITS - DOWNTOWN DEVELOPMENT - MAIN STREET						
5-7550-51.1100	REGULAR EMPLOYEES	180,000	21,481	11.9%		180,000
5-7550-51.2100	GROUP INSURANCE	25,000	4,696	18.8%		25,000
5-7550-51.2200	FICA (SOCIAL SECURITY)	1,500	288	19.2%		1,500
5-7550-51.2400	RETIREMENT	10,000	2,536	25.4%		10,000
5-7550-51.2700	WORKER'S COMPENSATION	6,000	2,627	43.8%		6,000
5-7550-51.2750	UNEMPLOYMENT TAX - GEORGIA	500	0	0.0%		500
TOTAL PERSONAL SVC & EMP BEN		223,000	31,628	14.2%	0	223,000
PURCHASED/CONTRACTED SVC - DOWNTOWN DEVELOPMENT - MAIN STREET						
5-7550-52.1200	PROFESSIONAL SVCS	15,000	0	0.0%	2500	17,500
5-7550-52.1230	LEGAL	1000	0	0.0%	500	1,500
5-7550-52.3300	ADVERTISING	30,000	0	0.0%		30,000
5-7550-52.3700	EDUCATION & TRAINING DDA	2,500	0	0.0%		2,500
5-7550-52.3970	POSTAGE	0	0	0.0%		0
5-7550-54.1300	TRAIN PLATFORM - Expense	12,000	230	1.9%		12,000
5-7550-52.1400	DRUG & MEDICAL	100	0	0.0%		100
5-7550-52.2250	OTHER EQUIP. REPAIRS/MAINT	500	0	0.0%		500
5-7540-52.2320	RENTAL EQUIPMENT	3,000	0	0.0%		3,000
5-7550-52.3100	RISK MANAGEMENT	4,500	0	0.0%		4,500
5-7550-52.3200	COMMUNICATIONS-CELL PHONE	1,000	524	52.4%		1,000
5-7550-52.3310	PUBLIC NOTICES	1,500	424	28.3%		1,500
5-7550-52.3500	TRAVEL-MILE REIMBURSEMENT	1300	0	0.0%		1,300
5-7550-52.3600	DUES & FEES	1,200	369	30.8%		1,200
5-7550-52.3700	EDUCATION & TRAINING	3,500	754	21.5%		3,500
5-7550-52.3750	MEETINGS & CONFERENCE	2,000	845	42.3%		2,000
5-7550-52.3855	EVENT ENTERTAINMENT CONTRACTS	20,500	575	2.8%	22200	42,700
5-7550-52.3970	POSTAGE	0	0	0.0%		0

Hotel/Motel - Main Street - DDA Fund 275		FY 22	YTD	70% FY22	Year 23	FY 23 Budget
5-7540-52.3999	MISCELLANEOUS	0	0	0.0%		0
	TOTAL PURCHASED/CONTRACTED SVC	99,600	3,721	3.7%	25,200	124,800
	SUPPLIES					
5-7550-53.1105	OFFICE SUPPLIES	2,000	0	0.0%		2,000
5-7550-53.1107	BANK & CREDIT CARD CHARGES	0	0	0.0%		0
5-7550-53.1160	OPERATING EQUIPMENT	1,500	0	0.0%		1,500
5-7550-53.1700	OTHER SUPPLIES	0	0	0.0%		0
5-7550-53.1720	CHRISTMAS DECORATIONS	15,000	0	0.0%	10,000	25,000
5-7550-53.1729	CITY EVENTS	75,000	1,000	1.3%		75,000
5-7550-53.1750	PROMOTIONS	15,000	0	0.0%		15,000
5-7550-53.1785	UNIFORMS	600	0	0.0%		600
	TOTAL SUPPLIES	109,100	1,000	0.9%	10,000	119,100
	CAPITAL OUTLAY					
5-7550-54.1100	LAND ACQUISITIONS	250,000	0	0.0%	24,800	274,800
5-7550-54.1150	FURNITURE & FIXTURES	3,000	0	0.0%		3,000
5-7550-54.1300	TRAIN PLATFORM	12,000	0	0.0%	10,000	22,000
5-7550-54.1400	BANNER PROGRAM	20,000	394	2.0%		20,000
5-7550-54.1500	WAYFINDING SIGNS	10,000	0	0.0%		10,000
5-7550-54.2400	COMPUTERS	3,000	0	0.0%		3,000
	TOTAL CAPITAL OUTLAY	298,000	394	0.1%	34,800	332,800
	PAYMENT TO OTHERS					
5-7550-57.3300	PARHAM PARKING LOT LEASE	5,000	0	0.0%		5,000
5-7550-57.3310	NORFOLK SOUTHERN LOT LEASE	500	466	93.2%		500
	TOTAL PAYMENT TO OTHERS	5,500	466	8.5%	0	5,500
	TOTAL ECONOMIC DEVELOPMENT	735,200	37,209	5.1%	70,000	805,200
	TOTAL Tourism and DD-Main Street	1,085,200	288,315	26.6%	165,000	1,250,200
	TOTAL EXPENDITURES	1,085,200	179,452	16.5%	165,000	1,250,200
	REVENUE OVER/(UNDER) EXPENDITURES	0	108,863	0.0%	0	0

SPLOST (IV and V)						
		FY23	YTD	Percent	Adjust.	Rev FY 23
SPLOST (IV and V)				0.0%		
REVENUES				0.0%		
				0.0%		
3-0000-31.3200	SPLOST V PROCEEDS	0	0	0.0%		0
3-0000-36.1000	INTEREST INCOME	1,730	6,991	404.1%		1,730
3-0000-36.1100	INTEREST REVENUE SPLOST 3	0	0	0.0%		0
3-0000-38.9000	MISCELLANEOUS REVENUE	0	0	0.0%		0
3-0000-38.9050	PRIOR YEAR REVENUE	2,312,000	0	0.0%		2,312,000
3-0000-39.1100	SPLOST BOND PROCEEDS	0	0	0.0%		0
3-0000-39.1200	COUNTY SPLOST IV PROCEEDS	0	0	0.0%		0
3-0000-39.1201	SPLOST V REVENUE	1,000,000	278,191	27.8%		1,000,000
TOTAL REVENUES		3,313,730	285,182	8.6%	0	3,313,730
5-1510-53.1107	BANK & CREDIT CARD CHARGES	120	40	33.3%	0	120
Total Supplies		120	40	33.3%	0	120
CAPITAL OUTLAY						
PUBLIC BUILDINGS				0.0%		
5-1510-54.1100	ACQUISTION OF PROPERTY	0	0	0.0%		0
5-1510-54.1302	BUILDING IMPROVEMENTS	0	0	0.0%		0
5-1510-54.1303	CONST/RENOV MUNICIPAL BLDG	576,250	0	0.0%	0	576,250
TOTAL PUBLIC BLDGS		576,250	0	0.0%	0	576,250
5-3230-54.1350	PUBLIC SAFETY FACILITIES/EQUIP	0	0	0.0%		0
TOTAL PUBLIC SAFETY		0	0	0.0%	0	0
ROADS AND BRIDGES						
5-4210-52.3851	CONTRACT SERVICES	0	0	0.0%		0
5-4210-54.1401	ROADS BRIDGES SIDEWALKS ETC.	100,000	0	0.0%	-78000	22,000
5-4210-54.1404	TANGER BLVD PROJECT	0	0	0.0%		0
5-4210-54.1405	BILL GARDNER IMP PROJECT	2,067,360	0	0.0%		2,067,360
5-4210-54.1406	SIGNAL @ MARKET PLACE	0	77,895	0.0%	78000	78,000
5-4210-54.1407	HWY 42 EXTRA LANE	0	0	0.0%		0
5-4210-54.1408	RESURFACING STREETS	320,000	0	0.0%		320,000
5-4210-54.1501	PEEKSVILLE CNNCTR SPLOST V CLE	0	0	0.0%		0
5-4210-54.1502	SR 42 EXTRA LANE BGP TO MKTPLC	150,000	0	0.0%		150,000
5-4210-54.1503	PEEKSVILLE RD.-PEDESTRIAN IMPR	0	0	0.0%		0
5-4210-54.1504	SR 42 & BETHLEHEM RD SIGNAL	100,000	0	0.0%		100,000
5-4210-54.1505	BICYCLE SHARED USE AREAS	0	0	0.0%		0
TOTAL ROADS/BRIDGES		2,737,360	77,895	2.8%	0	2,737,360
PARKS AND RECREATION						
5-6220-54.1402	PARKS & RECREATION FACILITIES	0	0	0.0%		0
5-6220-54.1410	TANGER SOFTBALL FIELDS	0	0	0.0%		0
TOTAL PARKS AND REC		0	0	0.0%	0	0
TOTAL OTHER USES						
5-8000-58.1201	SPLOST BOND PYMT PRINCIPAL	0	0	0.0%		0
5-8000-58.2201	SPLOST BOND PYMTS INTEREST	0	0	0.0%		0
TOTAL OTHER SOURCES/USES		0	0	0.0%	0	0
TOTAL REVENUES		3,313,730	285,182	8.6%	0	3,313,730
TOTAL EXPENDITURES		3,313,730	77,935	2.4%	0	3,313,730
REVENUE OVER/(UNDER) EXPENDITURES		0	207,248	0.0%	0	0

TSPLOST						
		FY23	YTD	Percent	Adjust.	Rev FY 23
TOTAL REVENUES				0.0%		
3-0000-31.3200	T-SPLOST PROCEEDS	1,100,000	189,966	17.3%		1,100,000
3-0000-36.1000	T-SPLOST INTEREST	-	-	0.0%		-
3-0000-38.9050	PRIOR YEAR REVENUE	6,000,000	-	0.0%		6,000,000
3-0000-39.1100	T-SPLOST BOND PROCEEDS	-	-	0.0%		-
** TOTAL REVENUES **	Total Revenues	7,100,000	189,966	2.7%	-	7,100,000
CONTRACTED SVCS						
5-1510-52.1230	LEGAL	-	-	0.0%		-
TOTAL CONTRACTED SVCS		-	-	0.0%	-	-
SUPPLIES						
5-1510-53.1107	BANK AND CREDIT CARD CHARGES	-	1,100	0.0%	2,500	2,500
TOTAL SUPPLIES		-	1,100	0.0%	2,500	2,500
CAPITAL OUTLAY						
5-1510-54.1100	ACQUISITION OF PROPERTY	-	-	0.0%	1,500,000	1,500,000
5-4210-54.1401	TARGETED PAVING	700,000	9,120	1.3%	650,000	1,350,000
5-4210-54.1402	SR 42 & BILL GARD CONGESTION	3,500,000	-	0.0%	(1,500,000)	2,000,000
5-4210-54.1403	BILL GARDNER IMPROVEMENTS	500,000	61,307	12.3%	(250,000)	250,000
5-4210-54.1404	SR 42 EXTRA LANE	600,000	-	0.0%	(200,000)	400,000
5-4210-54.1405	BETHLEHEM SIGNAL STUDY	-	-	0.0%		-
5-4210-54.1406	BIKEWAY/PEDESTRIAN	400,000	-	0.0%	(200,000)	200,000
TOTAL CAPITAL OUTLAY		5,700,000	70,427	1.2%		5,700,000
TOTAL STREET MAINTENANCE		5,700,000	70,427	1.2%	-	5,700,000
OTHER SOURCES/USES						-
5-8000-58.1201	T-SPLOST BOND PMT PRINCIPAL	1,200,000	-	0.0%		1,200,000
5-8000-58.2201	T-SPLOST BOND PYMT INTEREST	200,000	-	0.0%		200,000
TOTAL OTHER SOURCES/USES		1,400,000	-		-	1,400,000
TOTAL EXPENDITURES		7,100,000	70,427	1.0%	-	7,100,000
REVENUE & OTHER SOURCES OVER/ (UNDER) EXPENDITURES & OTHER USES		-	119,540		-	-

Development Impact Fees						
		FY23	YTD	Percent	Adjust.	Rev FY 23
NON-DEPARTMENTAL						
INVESTMENT INCOME						
3-0000-36.1000	INTEREST PD	125	813	650.8%	1,875	2,000
3-0000-36.1100	INTEREST PAID TO CDS	-	-	0.0%	-	-
TOTAL INVESTMENT INCOME		125	813	650.8%	1,875	2,000
MISCELLANEOUS REVENUE						
3-0000-38.9900	PRIOR YEAR REVENUE	-	-	0.0%	-	-
TOTAL MISCELLANEOUS REVENUE		-	-	0.0%	-	-
TOTAL NON-DEPARTMENTAL		125	813	650.8%	1,875	2,000
ADMINISTRATION						
CHARGES FOR SERVICES						
3-1510-34.6950	ADMINISTRATIVE FEE	15,000	2,427	16.2%	15,000	30,000
TOTAL CHARGES FOR SERVICES		15,000	2,427	16.2%	15,000	30,000
INVESTMENT INCOME						
3-1510-36.1000	ADMINISTRATIVE INTEREST	10	-	0.0%	-	10
TOTAL INVESTMENT INCOME		10	-	0.0%	-	10
TOTAL ADMINISTRATION		15,010	2,427	16.2%	15,000	30,010
CIE PREP						
CHARGES FOR SERVICES						
3-2500-34.6954	CIE PREP FUND	3,000	601	20.0%	-	3,000
TOTAL CHARGES FOR SERVICES		3,000	601	20.0%	-	3,000
INVESTMENT INCOME						
3-2500-36.1000	CIE INTEREST	10	-	0.0%	-	10
TOTAL INVESTMENT INCOME		10	-	0.0%	-	10
TOTAL CIE PREP		3,010	601	20.0%	-	3,010
POLICE DEPARTMENT						
CHARGES FOR SERVICES						
3-3230-34.6951	POLICE DEPARTMENT FUND	85,000	3,406	4.0%	(15,000)	70,000
TOTAL CHARGES FOR SERVICES		85,000	3,406	4.0%	(15,000)	70,000
INVESTMENT INCOME						
3-3230-36.1000	POLICE DEPARTMENT INTEREST	50	-	0.0%	-	50
TOTAL INVESTMENT INCOME		50	-	0.0%	-	50
TOTAL POLICE DEPARTMENT		85,050	3,406	4.0%	(15,000)	70,050
STREET DEPARTMENT						
CHARGES FOR SERVICES						
3-4210-34.6953	STREET/ROAD DEPT FUND	157,000	9,386	6.0%	(50,000)	107,000
TOTAL CHARGES FOR SERVICES		157,000	9,386	6.0%	(50,000)	107,000
INVESTMENT INCOME						
3-4210-36.1000	STREET/ROAD DEPT INTEREST	50	-	0.0%	-	50
TOTAL INVESTMENT INCOME		50	-	0.0%	-	50
TOTAL STREET DEPARTMENT		157,050	9,386	6.0%	(50,000)	107,050
PARK & RECREATION						
CHARGES FOR SERVICES						

3-6220-34.6952	PARK/RECREATION FUND	225,000	68,094	30.3%		225,000
TOTAL CHARGES FOR SERVICES		225,000	68,094	30.3%	-	225,000
INVESTMENT INCOME						
3-6220-36.1000	PARK/RECREATION INTEREST	50	-	0.0%		50
TOTAL INVESTMENT INCOME		50	-	0.0%	-	50
TOTAL PARK & RECREATION		225,050	68,094	30.3%	-	225,050
TOTAL REVENUES		485,295	84,728	17.5%	(48,125)	437,170
PURCHASED/CONTRACTED SVC				0.0%		
5-1510-52.1200	ADMIN PROFESSIONAL SERVICES	5,000	-	0.0%		5,000
TOTAL PURCHASED/CONTRACTED SVC		5,000	-	0.0%		5,000
SUPPLIES				0.0%		
5-1510-53.1107	ADMIN BANK CHARGES	-	-	0.0%		-
TOTAL SUPPLIES		-	-	0.0%		-
TOTAL ADMINISTRATION		5,000	-	0.0%	-	5,000
PURCHASED/CONTRACTED SVC				0.0%		
5-2500-52.1200	CIE PROFESSIONAL SERVICES	70,000	-	0.0%		70,000
TOTAL PURCHASED/CONTRACTED SVC		70,000	-	0.0%	-	70,000
TOTAL CIE PREP		70,000	-	0.0%	-	70,000
CAPITAL OUTLAY				0.0%		
5-3230-54.1302	POLICE DEPT BUILDING	59,125	-	0.0%	(20,125)	39,000
TOTAL CAPITAL OUTLAY		59,125	-	0.0%	(20,125)	39,000
TOTAL POLICE DEPARTMENT		59,125	-	0.0%	(20,125)	39,000
PURCHASED/CONTRACTED SVC				0.0%		
5-4210-52.2260	STREET/ROAD PAVING & FIXTURES	200,000	-	0.0%	(28,000)	172,000
TOTAL PURCHASED/CONTRACTED SVC		200,000	-	0.0%	(28,000)	172,000
TOTAL STREET DEPARTMENT		200,000	-	0.0%	(28,000)	172,000
PURCHASED/CONTRACTED SVC				0.0%		
5-6220-52.1200	PARK/RECREATION PROF SVC	1,000	-	0.0%		1,000
5-6220-52.1250	PARK IMPRVMTS-TANGER WALKING	25,000	-	0.0%		25,000
TOTAL PURCHASED/CONTRACTED SVC		26,000	-	0.0%		26,000
CAPITAL OUTLAY				0.0%		
5-6220-54.1100	PARKS & RECS CAPITAL SHARE	112,500	-	0.0%		112,500
5-6220-54.1250	TANGER WALKING PARK	-	-	0.0%		-
5-6220-54.1300	BUILDINGS/COMMUNITY CENTER	-	-	0.0%		-
5-6220-54.1302	PARK/RECREATION EQUIPMENT	12,670	-	0.0%		12,670
TOTAL CAPITAL OUTLAY		125,170	-	0.0%	-	125,170
TOTAL PARK & RECREATION		151,170	-	0.0%	-	151,170
TOTAL EXPENDITURES		485,295	-	0.0%	(48,125)	437,170
REVENUE OVER/(UNDER) EXPENDITURES		-	84,728	0.0%	-	-

	FY23	YTD	Percent	Adjust.	Rev FY 23
Water/Sewer Utilities 505/506					
NON-DEPARTMENTAL			0.0%		
MISCELLANEOUS REVENUE			0.0%		
3-0000-38.9050	2,230,650.00	0.00	0.0%	-376350	1,854,300
TOTAL MISCELLANEOUS REVENUE	2,230,650.00	0.00	0.0%	-376350	1,854,300
TOTAL NON-DEPARTMENTAL	2,230,650.00	0.00	0.0%	-376350	1,854,300
SEWER DEPARTMENT					
Revenues - Total					
3-4330-34.4255	2,475,000.00	557,426.61	22.5%		2,475,000
3-4330-34.4256	100.00	0.00	0.0%		100
3-4330-34.4260	85,000.00	2,332.62	2.7%		85,000
3-4330-34.6902	40,000.00	11,025.00	27.6%		40,000
3-4330-34.6904	0.00	0.00	0.0%		-
3-4330-34.6920	0.00	0.00	0.0%		-
3-4330-34.6950	22,500.00	7,715.22	34.3%	2500	25,000
3-4330-34.6995	0.00	0.00	0.0%		-
3-4330-36.1000	300.00	1,507.37	502.5%	5200	5,500
3-4330-37.1000	0.00	0.00	0.0%		-
3-4330-34.6904	405,000.00	89,230.75	22.0%		405,000
TOTAL SEWER DEPARTMENT	2,622,900.00	580,006.82	22.1%	7,700	2,630,600
WATER DEPARTMENT					
CHARGES FOR SERVICES					
3-4420-34.4210	2,300,000.00	589,685.87	25.6%		2,300,000
3-4420-34.4215	100.00	0.00	0.0%		100
3-4420-34.4220	100.00	0.00	0.0%		100
3-4420-34.4425	115,000.00	36,825.45	32.0%	10000	125,000
3-4420-34.6901	65,000.00	19,240.00	29.6%		65,000
3-4420-34.6903	429,200.00	0.00	0.0%		429,200
3-4420-34.6920	0.00	0.00	0.0%		0
3-4420-34.6950	33,000.00	9,797.39	29.7%		33,000

FY 23 Budget	Enterprise Fund(s) 505/506	Sewer (4330) / Water (4420)
3-4420-34.6963	RECONNECT FEES	7,700.00 17.1%
3-4420-34.6964	PHONE CC FEE	0.00 0.0%
3-4420-34.6995	MISCELLANEOUS	185.00 5.3%
3-4420-34.9300	BAD CHECK FEES	280.00 28.0%
3-4420-36.1000	INTEREST REVENUES	1,196.18 341.8%
3-4420-37.1000	CONTRIBUTED CAPITAL	0.00 0.0%
3-4420-38.1000	RENTS & ROYALTIES	0.00 0.0%
	TOTAL WATER DEPARTMENT	664,909.89 22.1%
	TOTAL REVENUES (includes 50% Prior Year)	1,244,916.71 15.8%
	PERSONAL SVC & EMP BEN	0.0%
		0.0%
5-4330-51.1100	REGULAR EMPLOYEES	57,762.45 21.0%
5-4330-51.1300	OVERTIME	7,939.92 10000 25,000
5-4330-51.2100	GROUP INSURANCE	6,204.59 33,000
5-4330-51.2200	FICA (SOCIAL SECURITY)	919.95 2,750
5-4330-51.2400	RETIREMENT	8,249.42 8500 32,500
5-4330-51.2700	WORKER'S COMPENSATION	7,881.60 8,000
5-4330-51.2750	UNEMPLOYMENT TAX - GEORGIA	0.00 1,000
	TOTAL PERSONAL SVC & EMP BEN	88,957.93 18,500 377,250
	PURCHASED/CONTRACTED SVC	
5-4330-52.1200	PROFESSIONAL	0.00 5,000
5-4330-52.1205	PROFESSIONAL SERVICES	5,027.30 14.4%
5-4330-52.1210	ADMIN FEE - SEWER TRANSFER OUT	0.00 355,000
5-4330-52.1230	LEGAL	0.00 500
5-4330-52.1250	ENGINEERING	0.00 300,000
5-4330-52.1400	DRUG & MEDICAL	0.00 1,000
5-4330-52.2210	AUTO / TRUCK EXPENSES	983.29 6,000
5-4330-52.2211	AUTO GAS & FUEL	1,767.45 15,500
5-4330-52.2212	CAR ALLOWANCE	0.00 0
5-4330-52.2240	BUILDING & GROUNDS	4,291.54 7500 17,500
5-4330-52.2250	PLANT EQUIP REPAIRS/MAINT	83,670.92 50000 250,000
5-4330-52.2255	SEW COLLECTION EQUIP REPAIRS/M	152,738.78 50000 275,000
5-4330-52.2256	REPAIRS TO SEWER LINES	0.00 -25000 175,000
5-4330-52.2330	EQUIPMENT LEASING	12,931.68 10000 17,000
5-4330-52.3100	RISK MANAGEMENT INSURANCE	0.00 7,500
5-4330-52.3200	COMMUNICATION CELL PHONES	1,542.15 4,000

	TELEPHONE	0.00	0.00	0.00	0.0%	0
5-4330-52.3201	TELEPHONE		0.00	0.00	0.0%	0
5-4330-52.3205	INTERNET		0.00	0.00	0.0%	0
5-4330-52.3310	PUBLIC NOTICES		500.00	386.00	77.2%	500
5-4330-52.3600	DUES & FEES		5,000.00	2,923.25	58.5%	0
5-4330-52.3601	FINES AND PENALTIES		2,500.00	0.00	0.0%	2500
5-4330-52.3700	EDUCATION & TRAINING		10,000.00	475.00	4.8%	10,000
5-4330-52.3857	WASTE WATER TESTS		15,000.00	19,417.91	129.5%	10000
5-4330-52.3858	CHEMICALS WASTEWATER		95,000.00	37,954.39	40.0%	0
5-4330-52.3862	SLUDGE REMOVAL		100,000.00	22,269.81	22.3%	100,000
5-4330-52.3970	POSTAGE		5,000.00	3,280.00	65.6%	2500
	TOTAL PURCHASED/CONTRACTED SVC		1,704,500.00	349,659.47	20.5%	8,000
	SUPPLIES					
5-4330-53.1105	OFFICE SUPPLIES		1,500.00	293.67	19.6%	1,500
5-4330-53.1107	BANK & CREDIT CARD CHARGES		250.00	0.00	0.0%	250
5-4330-53.1150	OPERATING SUPPLIES		30,000.00	1,458.80	4.9%	30,000
5-4330-53.1161	LAB SUPPLIES		20,000.00	8,176.56	40.9%	20,000
5-4330-53.1205	UTILITIES		225,000.00	53,807.85	23.9%	225,000
5-4330-53.1210	STORMWATER FEES		2,000.00	0.00	0.0%	2,000
5-4330-53.1700	OTHER SUPPLIES		500.00	0.00	0.0%	500
5-4330-53.1775	REPAIR DAMAGE PROPERTY		0.00	0.00	0.0%	0
5-4330-53.1785	UNIFORMS		5,500.00	1,224.21	22.3%	5,500
5-4330-53.1786	BOOT ALLOWANCE		600.00	0.00	0.0%	600
5-4330-53.1795	MISCELLANEOUS		0.00	0.00	0.0%	0
	TOTAL SUPPLIES		285,350.00	64,961.09	22.8%	285,350
	CAPITAL OUTLAY					
5-4330-54.1202	ABANDON SKYLAND WPCP		0.00	0.00	0.0%	-
5-4330-54.1203	ABANDON WEST POND		0.00	0.00	0.0%	-
5-4330-54.1420	INDIAN CREEK WPCP		1,000,000.00	147,057.01	14.7%	(600,000.00)
5-4330-54.1421	South Ola Lift Station (Renamed)		350,000.00	0.00	0.0%	(25,000.00)
5-4330-54.1422	Richmond Park Lift Station (Ren)		350,000.00	0.00	0.0%	(25,000.00)
5-4330-54.1423	DAVIS LAKE LINE EXT - NEW		0.00	0.00	0.0%	-
5-4330-54.1424	SEWER SYST. IMPROVE SWR LINES		300,000.00	0.00	0.0%	(75,000.00)
5-4330-54.2130	SCADA SYSTEM		150,000.00	0.00	0.0%	150,000.00
5-4330-54.2200	VEHICLES		50,000.00	0.00	0.0%	50,000.00
5-4330-54.2251	CAPITAL LEASE 2019 JD EXCAVATO		0.00	0.00	0.0%	-

5-4330-54.2400	COMPUTERS	1,500.00	0.00	0.0%	0.0%	1,500.00
5-4330-54.2450	COMPUTER MAINTENANCE	0.00	0.00	0.0%	0.0%	-
5-4330-54.2500	EQUIPMENT	35,000.00	138,269.79	395.1%	150,000.00	185,000.00
TOTAL CAPITAL OUTLAY		2,201,500.00	147,057.01	6.7%	(725,000.00)	1,476,500.00
DEPRECIATION & AMORT						
TOTAL DEPRECIATION & AMORT			0.00	0.0%	-	0
5-4330-56.1000	DEPRECIATION	0.00	0.00	0.0%	0.0%	-
DEBT SERVICE						
5-4330-57.4000	BAD DEBT	0.00	0.00	0.0%	0.0%	
5-4330-57.9000	CONTINGENCIES	25,000.00	0.00	0.0%	0.0%	25,000
5-4330-58.1207	W&S BOND PRINCIPAL	400,000.00	96,687.48	24.2%	0	400,000
5-4330-58.2207	W/S BOND INTEREST	65,000.00	12,528.75	19.3%	-25000	40,000
TOTAL DEBT SERVICE		490,000.00	109,216.23	22.3%	-25,000	465,000
TOTAL SEWER DEPARTMENT		5,040,100.00	759,851.73	15.1%	(723,500.00)	4,316,600
Total Sewer Revenues		4,295,887.50	580,006.82		(180,475.00)	4,115,413
Total Over/(Under) Revenues		(744,212.50)	(179,844.91)		543,025.00	(201,187.50)
PERSONAL SVC & EMP BEN						
5-4420-51.1100	REGULAR EMPLOYEES	325,000.00	49,893.45	15.4%		325,000
5-4420-51.1300	OVERTIME	7,000.00	5,224.54	74.6%	3000	10,000
5-4420-51.2100	GROUP INSURANCE	30,000.00	6,160.26	20.5%		30,000
5-4420-51.2200	FICA (SOCIAL SECURITY)	3,000.00	776.73	25.9%		3,000
5-4420-51.2400	RETIREMENT	13,500.00	4,667.67	34.6%	5000	18,500
5-4420-51.2700	WORKER'S COMPENSATION	5,000.00	3,940.80	78.8%		5,000
5-4420-51.2750	UNEMPLOYMENT TAX - GEORGIA	1,000.00	0.00	0.0%		1,000
TOTAL PERSONAL SVC & EMP BEN		384,500.00	70,663.45	18.4%		384,500
PURCHASED/CONTRACTED SVC						
5-4420-52.1200	PROFESSIONAL	5,000.00	0.00	0.0%		5,000
5-4420-52.1210	ADMIN FEE - WATER TRANSFER OUT	400,000.00	0.00	0.0%	50000	450,000
5-4420-52.1230	LEGAL	1,000.00	0.00	0.0%		1,000
5-4420-52.1250	ENGINEERING	35,000.00	6,766.01	19.3%		35,000
5-4420-52.1400	DRUG & MEDICAL	500.00	0.00	0.0%		500

FY 23 Budget	Enterprise Fund(s) 505/506	Sewer (4330) / Water (4420)			
5-4420-52.2210	AUTO / TRUCK EXPENSE	20,000.00	2,271.55	11.4%	20,000
5-4420-52.2211	AUTO GAS & FUEL	15,000.00	1,843.49	12.3%	15,000
5-4420-52.2240	BUILDING & GROUNDS	3,000.00	0.00	0.0%	3,000
5-4420-52.2250	TREATMENT - REPAIRS & MAINT.	60,000.00	1,450.93	2.4%	60,000
5-4420-52.2256	DISTRIBUTION REPAIR WATER LIN	95,000.00	16,902.38	17.8%	95,000
5-4420-52.2257	REPAIR / MAINTENANCE TANKS	75,000.00	13,110.75	17.5%	75,000
5-4420-52.2258	WELL REPAIRS	45,000.00	5,551.19	12.3%	45,000
5-4420-52.2320	RENTAL EQUIP / VEHICLE	1,000.00	0.00	0.0%	1,000
5-4420-52.3100	RISK MANAGEMENT INSURANCE	7,000.00	0.00	0.0%	7,000
5-4420-52.3200	COMMUNICATION CELL PHONES	2,500.00	827.76	33.1%	2,500
5-4420-52.3201	TELEPHONE	0.00	0.00	0.0%	0
5-4420-52.3205	INTERNET	0.00	0.00	0.0%	0
5-4420-52.3310	PUBLIC NOTICES	0.00	0.00	0.0%	0
5-4420-52.3600	DUES & FEES	5,000.00	2,774.31	55.5%	5,000
5-4420-52.3700	EDUCATION & TRAINING	5,000.00	0.00	0.0%	5,000
5-4420-52.3750	MEETINGS & CONFERENCES	1,000.00	0.00	0.0%	1,000
5-4420-52.3855	DRINKING WATER FEES CONTRACT	25,000.00	0.00	0.0%	25,000
5-4420-52.3856	WATER TESTING	10,000.00	445.90	4.5%	10,000
5-4420-52.3859	CHEMICALS FOR WATER	30,000.00	5,530.98	18.4%	30,000
5-4420-52.3970	POSTAGE	1,000.00	0.00	0.0%	1,000
TOTAL PURCHASED/CONTRACTED SVC		842,000.00	57,475.25	6.8%	842,000
SUPPLIES					
5-4420-53.1105	OFFICE SUPPLIES	2,000.00	480.61	24.0%	2,000
5-4420-53.1107	BANK & CREDIT CARD CHARGES	1,200.00	0.00	0.0%	1,200
5-4420-53.1150	OPERATING SUPPLIES	45,000.00	3,830.94	8.5%	45,000
5-4420-53.1205	UTILITIES	50,000.00	8,399.34	16.8%	50,000
5-4420-53.1210	STORM WATER FEES	1,200.00	0.00	0.0%	1,200
5-4420-53.1510	INV PCH WATER FOR RESALE	560,000.00	102,043.96	18.2%	500,000
5-4420-53.1775	REPAIR DAMAGE PROPERTY	0.00	0.00	0.0%	0
5-4420-53.1785	UNIFORMS	5,000.00	1,254.78	25.1%	5,000
5-4420-53.1786	BOOT ALLOWANCE	600.00	0.00	0.0%	600
5-4420-53.1795	MISCELLANEOUS	0.00	0.00	0.0%	0
TOTAL SUPPLIES		665,000.00	116,009.63	17.4%	665,000
CAPITAL OUTLAY					
5-4420-54.1430	TEST WELLS	0.00	0.00	0.0%	0

5-4420-54.1440	WATER TANK DEVELOPMENT	0.00	0.00	0.00	0.0%	0
5-4420-54.1442	WELL DEVELOPMENT	0.00	0.00	0.00	0.0%	0
5-4420-54.1445	WATER SYSTEM IMPROVEMENTS	295,000.00	95,001.88	32.2%		295,000
5-4420-54.2110	NEW METER INSTALLATIONS	225,000.00	4,652.66	2.1%		225,000
5-4420-54.2120	RADIO READ SYSTEM	150,000.00	0.00	0.0%		150,000
5-4420-54.2130	SCADA SYSTEM	25,000.00	0.00	0.0%		25,000
5-4420-54.2200	VEHICLES	50,000.00	0.00	0.0%		50,000
5-4420-54.2400	COMPUTERS	1,200.00	0.00	0.0%		1,200
5-4420-54.2450	COMPUTER MAINTENANCE	0.00	0.00	0.0%		0
5-4420-54.2500	EQUIPMENT	25,000.00	0.00	0.0%		25,000
TOTAL CAPITAL OUTLAY		771,200.00	99,654.54	12.9%		771,200
TOTAL DEPRECIATION & AMORT				0.0%		
PAYMENT TO OTHERS				0.0%		
				0.0%		
5-4420-56.1000	DEPRECIATION	0.00	0.00	0.0%		0
5-4420-56.1100	AMORTIZATION EXPENSE	0.00	0.00	0.0%		0
5-4420-57.1000	SDS HCWA IF	215,000.00	23,100.00	10.7%		215,000
TOTAL PAYMENT TO OTHERS		215,000.00	23,100.00	10.7%		215,000
DEBT SERVICE				0.0%		
				0.0%		
5-4420-57.4000	BAD DEBTS	0.00	0.00	0.0%		0
5-4420-57.900	CONTINGENCIES	25,000.00	0.00	0.0%		25,000
5-4420-58.1208	W/S BOND PRINCIPAL	225,000.00	52,062.51	23.1%		225,000
5-4420-58.2208	W&S BOND INTEREST	66,000.00	6,746.25	10.2%		66,000
TOTAL DEBT SERVICE		316,000.00	58,808.76	18.6%		316,000
TOTAL WATER DEPARTMENT		3,193,700.00	425,711.63	13.3%		3,193,700
Total Water Revenues		3,567,912.50	664,909.89			3,488,975
Revenues Over/(Under) Exp		374,212.50	239,198.26			295,275
TOTAL EXPENDITURES		8,233,800.00	1,185,563.36	14.4%		7,510,300
TOTAL REVENUES		7,863,800.00	1,244,916.71	15.8%		7,510,300
REVENUE OVER/(UNDER) EXPENDITURES		(370,000.00)	59,353.35			370,000

Sanitation Fund 540		Original 23	YTD	25% of FY	Amend	Rev FY 23
Sanitation Fund 540						
NON-DEPARTMENTAL						
CHARGES FOR SERVICES						
3-0000-34.4101	RESIDENTIAL SANITATION	710,500	186,693	26.3%	24000	734,500
3-0000-34.4102	COMMERCIAL SANITATION	12,500	3,269	26.2%		12,500
3-0000-34.4103	CHIPPING FEES	500	-	0.0%		500
3-0000-34.4150	COLLECTION SITE FEES	20,000	2,960	14.8%		20,000
3-0000-34.4160	RECYCLE PROCEEDS	5,000	477	9.5%		5,000
TOTAL CHARGES FOR SERVICES		748,500	193,399	25.8%	24,000	772,500
MISCELLANEOUS REVENUE						
3-0000-34.4190 SANITATION OTHER CHARGES						
TOTAL MISCELLANEOUS REVENUE		-	-	0.0%	-	-
OTHER FINANCIAL SOURCES						
3-0000-38.9050 PRIOR YEAR REVENUE						
3-0000-39.1100 OPERATING TRANSFER						
3-0000-64.6950 SANITATION PENALTIES						
TOTAL OTHER FINANCIAL SOURCES		10,000	2,714	27.1%	-	10,000
TOTAL NON-DEPARTMENTAL		758,500	196,113	25.9%	24,000	782,500
TOTAL REVENUES		758,500	196,113	25.9%	24,000	782,500
PERSONAL SVC & EMP BEN						
5-0000-51.1100 REGULAR EMPLOYEES						
5-0000-51.1300 OVERTIME						
5-0000-51.2100 GROUP INSURANCE						
5-0000-51.2200 FICA (SOCIAL SECURITY)						
5-0000-51.2400 RETIREMENT						
5-0000-51.2700 WORKER'S COMPENSATION						
5-0000-51.2750 UNEMPLOYMENT TAX - GEORGIA						
TOTAL PERSONAL SVC & EMP BEN		122,000	26,363	21.6%	-1,500	120,500
PURCHASED/CONTRACTED SVC						
5-0000-52.1210 ADMIN FEE - SANIT TRANSFER OUT						
5-0000-52.1400 DRUG & MEDICAL						
5-0000-52.2210 AUTO/TRUCK EXPENSES						
5-0000-52.2211 AUTO GAS & FUEL						
5-0000-52.2240 BUILDING & GROUNDS						
5-0000-52.2250 OTHER EQUIP. REPAIRS/MAINT						
5-0000-52.3100 RISK MANANGEMENT INSURANCE						
5-0000-52.3200 COMMUNICATION CELL PHONE						
5-0000-52.3205 INTERNET						
5-0000-52.3310 PUBLIC NOTICES						
5-0000-52.3600 DUES & FEES						
5-0000-52.3700 EDUCATION & TRAINING						
5-0000-52.3860 SANITATION CONTRACT						
5-0000-52.3861 TIPPING FEE FOR LANDFILL						
5-0000-52.3862 ROLLOFF COLLECTIONS						
5-0000-52.3863 TIRE DISPOSAL FEE						
5-0000-52.3970 POSTAGE						
TOTAL PURCHASED/CONTRACTED		591,750	156,607	26.5%	-9,750	582,000
SUPPLIES						
5-0000-53.1150 OPERATING SUPPLIES						

Sanitation Fund 540		Original 23	YTD	25% of FY	Amend	Rev FY 23
Sanitation Fund 540						
5-0000-53.1160	OPERATING EQUIPMENT	7,500	2,060	27.5%		7,500
5-0000-53.1205	UTILITIES	1,500	147	9.8%		1,500
5-0000-53.1700	OTHER SUPPLIES	2,500	-	0.0%		2,500
5-0000-53.1785	UNIFORMS	2,500	242	9.7%		2,500
5-0000-53.1786	BOOT ALLOWANCE	500	-	0.0%		500
5-0000-53.1795	MISCELLANEOUS	-	-	0.0%		-
TOTAL SUPPLIES		14,500	2,526	17.4%	500	15,000
CAPITAL OUTLAY						
5-0000-54.2200	VEHICLES	25,000	-	0.0%		25,000
5-0000-54.2450	COMPUTER MAINTENANCE	-	-	0.0%		-
5-0000-54.2500	EQUIPMENT	5,250	-	0.0%	34750	40,000
TOTAL CAPITAL OUTLAY		30,250	-	0.0%	34,750	65,000
DEPRECIATION & AMORT						
5-0000-56.1000	DEPRECIATION EXPENSE	-	-	0.0%		-
TOTAL DEPRECIATION & AMORT		-	-	0.0%		
TOTAL NON-DEPARTMENTAL		758,500	196,113	25.9%	24,000	782,500
TOTAL EXPENDITURES		758,500	185,496	24.5%	24,000	782,500
REVENUE OVER/(UNDER) EXPENDITURES		0	10,616	0.0%	0	0

Stormwater Fund 570		Original 23	YTD	25% of FY	Amend	Rev FY 23
Stormwater Fund 570						
CHARGES FOR SERVICES						
3-0000-34.4261	STORM UTILITY FEE	475,000	5,679	1.2%		475,000
TOTAL OTHER FINANCIAL SOURCES		475,000	5,679	1.2%	0	475,000
3-0000-38.9050	PRIOR YEAR REVENUE	19,650	0	0.0%		19,650
3-0000-39.1100	OPERATING TRANSFER	0	0	0.0%		0
TOTAL NON-DEPARTMENTAL		19,650	0	0.0%	0	19,650
TOTAL REVENUES		494,650	5,679	1.1%	0	494,650
PERSONAL SVC & EMP BEN						
5-0000-51.1100	REGULAR EMPLOYEES	145,000	29,595	20.4%		145,000
5-0000-51.1300	OVERTIME	1,500	1,111	74.1%		1,500
5-0000-51.2100	GROUP INSURANCE	37,500	14,254	38.0%	12500	50,000
5-0000-51.2200	FICA (SOCIAL SECURITY)	2,000	415	20.8%		2,000
5-0000-51.2400	RETIREMENT	15,000	3,089	20.6%		15,000
5-0000-51.2500	TUITION REIMBURSEMENTS	0	0	0.0%		0
5-0000-51.2700	WORKER'S COMPENSATION	4,500	2,627	58.4%	-1500	3,000
5-0000-51.2750	UNEMPLOYMENT TAX - GEORGIA	500	0	0.0%		500
TOTAL PERSONAL SVC & EMP BEN		206,000	51,092	24.8%	11,000	217,000
PURCHASED/CONTRACTED SVC						
5-0000-52.1200	PROFESSIONAL	30,000	0	0.0%		30,000
5-0000-52.1210	ADMIN FEE - STORM TRANSFER OUT	65,000	0	0.0%	-25000	40,000
5-0000-52.1230	LEGAL	250	0	0.0%		250
5-0000-52.1280	FLOODPLAIN MAPPING	500	0	0.0%		500
5-0000-52.1400	DRUG & MEDICAL	250	0	0.0%		250
5-0000-52.2210	AUTO/TRUCK EXPENSES	10,000	2,086	20.9%		10,000
5-0000-52.2211	AUTO GAS & FUEL	10,000	1,366	13.7%		10,000
5-0000-52.2250	OTHER EQUIP. REPAIRS/MAINT	25,000	639	2.6%		25,000
5-0000-52.3100	RISK MANAGEMENT INSURANCE	5,000	0	0.0%		5,000
5-0000-52.3200	COMMUNICATION CELL PHONES	1,500	586	39.1%		1,500
5-0000-52.3205	INTERNET	0	0	0.0%		0
5-0000-52.3310	PUBLIC NOTICES	0	0	0.0%		0
5-0000-52.3600	DUES & FEES	1,000	274	27.4%		1,000
5-0000-52.3700	EDUCATION & TRAINING	3,500	0	0.0%	-500	3,000
5-0000-52.3751	PUBLIC OUTREACH	5,000	69	1.4%	-500	4,500
5-0000-52.3800	POND MAINTENANCE	55,000	0	0.0%	-25000	30,000
5-0000-52.3855	CONTRACTS	0	1,354	0.0%		0
5-0000-52.3970	POSTAGE	0	37	0.0%		0
TOTAL PURCHASED/CONTRACTED SVC		212,000	6,412	3.0%	-51,000	161,000
SUPPLIES				0.0%		
				0.0%		
5-0000-53.1105	OFFICE SUPPLIES	200	0	0.0%		200
5-0000-53.1150	OPERATING SUPPLIES	3,500	602	17.2%		3,500
5-0000-53.1160	OPERATING EQUIPMENT	2,000	1,261	63.0%		2,000
5-0000-53.1200	FEE FOR COLLECTING TAX	2,500	0	0.0%		2,500
5-0000-53.1700	OTHER SUPPLIES	1,000	0	0.0%		1,000
5-0000-53.1785	UNIFORMS	750	0	0.0%		750
5-0000-53.1786	BOOT ALLOWANCE	200	0	0.0%		200
5-0000-53.1795	MISCELLANEOUS	0	0	0.0%		0
TOTAL SUPPLIES		10,150	1,863	18.4%	0	10,150
CAPITAL OUTLAY				0.0%		
				0.0%		
5-0000-54.2200	VEHICLES	0	0	0.0%		0
5-0000-54.2241	CAPITAL LEASE JD 333G	0	0	0.0%		0

Stormwater Fund 570						
		Original 23	YTD	25% of FY	Amend	Rev FY 23
Stormwater Fund 570						
5-0000-54.2242	CAPITAL LEASE 2019 JD EXCAVATO	0	0	0.0%		0
5-0000-54.2250	CAPITAL LEASE/BOBCAT W/DH80	55,000	0	0.0%		55,000
5-0000-54.2300	FURNITURE / FIXTURES	0	0	0.0%		0
5-0000-54.2400	COMPUTERS	1,500	0	0.0%		1,500
5-0000-54.2450	COMPUTER MAINTENANCE	0	0	0.0%		0
5-0000-54.2500	EQUIPMENT	10,000	0	0.0%	10000	20,000
5-0000-54.2601	DRAINAGE IMPROVEMENT	0	0	0.0%	30000	30,000
TOTAL CAPITAL OUTLAY		66,500	0	0.0%	40,000	106,500
DEPRECIATION & AMORT				0.0%		
5-0000-56.1000	DEPRECIATION EXPENSE	0	0	0.0%	0	0
TOTAL DEPRECIATION & AMORT		0	0	0.0%	0	0
PAYMENT TO OTHERS				0.0%		
TOTAL PAYMENT TO OTHERS		0	0	0.0%	0	0
TOTAL NON-DEPARTMENTAL		494,650	5,679	1.1%	0	494,650
TOTAL EXPENDITURES		494,650	59,367	12.0%	0	494,650
REVENUE OVER/(UNDER) EXPENDITURES		0	-53,688		0	0



Community Development Department

P. O. Box 900
Locust Grove, Georgia 30248

Phone: (770) 957-5043
Facsimile (770) 954-1223

Item Coversheet

Item: Special Event Permit request from TNT Fireworks for a fireworks sale to benefit Rainbow Girls, a non-profit organization.

Action Item: Yes No

Public Hearing Item: Yes No

Executive Session Item: Yes No

Advertised Date: NA

Budget Item: NA

Date Received: May 24, 2023

Workshop Date: N/A

Regular Meeting Date: June 5, 2023

Discussion:

Applicant:

TNT Fireworks
c/o David Midgorden
136 Glenn Groover Road
Hinesville, GA 31313

Staff received a request for a Special Events Permit from David Midgorden on behalf of TNT Fireworks seeking permission to sell fireworks from a tent in the Walmart parking lot from June 22-July 10, 2023 and December 25-31, 2023.

- Music and entertainment
 - None

- Food and drink prepared and consumed on-site
 - **None**
- Event location(s)
 - **4949 Bill Gardner Parkway – Walmart parking lot only**
- The duration of the event (including set up and break down)
 - **June 22 - July 10, 2023 (10am – 10pm)**
 - **December 25 - 31 2023 (10am – 10pm)**
- Contact information for the person who will be onsite during the event
 - **Ann Thompson – 404-444-7622**
- Which merchants will have booths at the event?
 - **TNT Fireworks**
- Permission from property owner at site:
 - **Yes, written permission has been provided for the July 4th sales. A second letter of written permission for the December sale will be provided prior to the event.**

Comments:

In Georgia, all fireworks classified as DOT 1.4G (consumer fireworks) are legal to purchase and use as stated in Georgia General Assembly House Bill 727. Consumer fireworks that you can legally buy in retail stores across Georgia include:

- Bottle Rockets
- Sky Rockets
- Roman Candles
- Firecrackers
- Sparklers
- Smoke and Punk (similar to incense)
- Fountains
- Missiles
- Novelties
- Crackle and Strobe
- Parachutes
- Wheels and Spinners
- Sky Flyers
- Display Shells
- Aerial Items (Cakes)

Who can buy Consumer Fireworks in Georgia:

You must be 18 years or older to buy fireworks. The law doesn't stipulate an exact age for igniting them. It is illegal to light fireworks while under the influence of drugs and/or alcohol.

When can you light Consumer Fireworks in Georgia:

Legally, you can only ignite fireworks up until a certain hour depending on the holiday. The legal time frame for when fireworks can be legally ignited is:

- New Years: until 1 AM
- Fourth of July: until midnight
- Any other day: not after 9 PM

A Temporary Certificate of Occupancy for the tent from the Henry County Fire Department shall be required prior to the start of the Special Event.

This request is on behalf of a non-profit organization, International Order of the Rainbow Girls.

Recommendation:

STAFF RECOMMENDS APPROVAL OF THE SPECIAL EVENT REQUEST MADE BY TNT FIREWORKS TO SELL FIREWORKS FROM JUNE 22 - JULY 10, 2023 AND DECEMBER 25-31, 2023 WITH THE FOLLOWING CONDITION:

- 1. A TEMPORARY CERTIFICATE OF OCCUPANCY FOR THE TENT SHALL BE ISSUED PRIOR TO THE START OF THIS SPECIAL EVENT.**



SPECIAL EVENTS PERMIT APPLICATION

Applicant: David Midgorden	Submittal Date: 23 May 2023
Organization: Rainbow Girls	Event Date(s)*: 22 June 2023
Type of Event: Fundraiser	Event Time(s): 10am - 10pm

***Please provide the following information a minimum of thirty (30) days prior to the event date.**

This request will be placed on the next available City Council agenda for a hearing.

The applicant (or designated representative) must attend this hearing.

Applicant's local address:	136 Glenn Groover Rd. Hinesville ga 31313
Applicant's e-mail address:	midgordend@tntfireworks.com
Location of the Event:	4949 BILL GARDNER PKWY LOCUST GROVE GA 30248
Name and telephone number of onsite contact who will be onsite for the duration of the event.	Ann Thompson 4044447622
Description of the nature of the special event:	Sale of GA legal fireworks
Identify sponsors and/or merchants participating in the event.	TNT Fireworks
Identify types of goods to be sold*, if any <i>*Additional permits may be required</i>	See attachment
Duration of the event (including setup and take down)	6/22-7/10, 12/25-12/31
Description of music/entertainment*: <i>*City's Noise Ordinance prohibits loud music/voices after midnight.</i>	n/a

Additional required information:

- Written permission from the property owner
- Legible copy of the applicant's driver's license (or other State issued ID)
- If the event is a road race, parade, march, running or cycling along public streets, attach a proposed route for review and approval.
 - List number of police officers/public works staff requested – additional fees may apply
- All fees* are payable to the City of Locust Grove in the amount of \$150
**If the event is for a non-profit organization wishing to waive the fees, proof of the organization's non-profit status must be submitted.*
- **FOR PROFIT EVENTS ONLY:** Complete the "Georgia Bureau of Investigation – Georgia Crime Information Center Consent Form" for a background check.
- **FOR PROFIT EVENTS ONLY:** Complete the attached "E-Verify Affidavit"
- **FOR PROFIT EVENTS ONLY:** Complete the attached "Affidavit Verifying Status for Receipt of Public Benefits"

Signature: _____ Date: _____ 23 June 2023 _____



AFFIDAVIT VERIFYING STATUS for RECEIPT OF PUBLIC BENEFITS
O.C.G.A. § 50-36-1(e)(2) AFFIDAVIT

By executing this affidavit under oath, as an applicant for the City of Locust Grove, Georgia public benefit (defined below), as supplemented by resolution of the City Council, and as referenced in O.C.G.A. § 50-36-1, I am stating the following with respect to my application to the City of Locust Grove:

 x I am a United States citizen.

OR

 I am a legal permanent resident 18 years of age or older, or I am an otherwise qualified alien or non-immigrant under the Federal Immigration and Nationality Act 18 years of age or older and lawfully present in the United States.*

I understand that “public benefit” includes but is not limited to: Adult education; Authorization to conduct a commercial enterprise or business; Authorization to conduct activities regulated by local government such as flea markets, peddlers, sidewalk vendors, massage therapy, bingo games, adult entertainment, pawn shops, day cares, etc.; Business certificate, license, or registration; Business loan; Cash allowance; Contract for materials or services; Disability assistance or insurance; Down payment assistance; Energy assistance; Food stamps; Gaming license; Health benefits; Housing allowance, grant, guarantee, or loan; Home occupation certificate, license, license and registration; Loan guarantee; Medicaid; Occupational license; Professional license; Registration of a regulated business; Rent assistance or subsidy; Retirement benefits; State grant or loan; State identification card; Tax certificate required to conduct a commercial business; Temporary assistance for needy families (TANF); Unemployment insurance; Vehicles for Hire certificate or license; and Welfare to work.

David Midgorden

Name of natural person applying on behalf of individual, business, corporation, partnership or other private entity

136 Glenn Groover rd. Hinesville Ga. 31313

Address of applicant named above

912-271-9772

Telephone Number

TNT Fireworks

Name of individual, business, corporation, partnership or other private entity for whom application is being made

Category of Public Benefit

In making the above representations under oath, I understand that any person who knowing and willfully makes a false, fictitious or fraudulent statement or representation in an affidavit shall be guilty of a violation of O.C.G.A. § 16-10-20.

Signature of Applicant

23 June 2023

Date

David Midgorden
Printed Name

*Alien Registration Number for Non-citizens



SUBSCRIBED AND SWORN
BEFORE ME ON THIS 23rd
DAY OF May 2023

NOTARY PUBLIC
MY COMMISSION EXPIRES: 3/17/26

Internal Revenue Service

Date: January 25, 2007

INTERNATIONAL ORDER OF THE RAINBOW GIRLS
SUPREME ASSEMBLY
PO BOX 1868
MCALESTER OK 74502

Department of the Treasury
P. O. Box 2508
Cincinnati, OH 45201

Person to Contact:
Paul Perry 31-07423
Customer Service Representative
Toll Free Telephone Number:
877-829-5500
Federal Identification Number:
73-0474600
Group Exemption Number:
5329

Dear Sir or Madam:

This is in response to your request of January 25, 2007, regarding your organization's tax-exempt status.

In August 1928 we issued a determination letter that recognized your organization as exempt from federal income tax. Our records indicate that your organization is currently exempt under section 501(c)(3) of the Internal Revenue Code.

Our records indicate that your organization is also classified as a public charity under sections 509(a)(1) and 170(b)(1)(A)(vi) of the Internal Revenue Code.

Based on the information supplied, we recognized the subordinates named on the list your organization submitted as exempt from federal income tax under section 501(c)(3) of the Code.

Our records indicate that contributions to your organization are deductible under section 170 of the Code, and that you are qualified to receive tax deductible bequests, devises, transfers or gifts under section 2055, 2106 or 2522 of the Internal Revenue Code.

If you have any questions, please call us at the telephone number shown in the heading of this letter.

Sincerely,

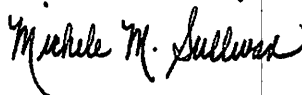

Michele M. Sullivan, Oper. Mgr.
Accounts Management Operations 1



702 SW 8th Street
Bentonville, AR 72716
Jasmine.Allen@walmart.com

February 23, 2023

To Whom It May Concern,

American Promotional Events, Inc. dba TNT Fireworks is an approved National Supplier to conduct fireworks promotions on our Walmart parking lots where this type of promotion is legal. All stores have been researched and approved by the Walmart Realty Department. Approximate time frame for the select stores approved for additional selling date promotions are:

- May 20, 2023 through and including July 12, 2023 with the exception of Utah which has an additional selling period through the end of July for Pioneer Days.

American Promotional Events, Inc. dba TNT Fireworks is authorized to sign for and obtain all necessary permits and/or licenses for the promotion and must display such permits and/or licenses at each stand/tent. Walmart grants permission for all patrons of the sale to utilize the restroom facilities at each participating store.

An American Promotional Events, Inc. dba TNT Fireworks representative will call you to introduce the company and discuss your participation in the event. Participation is encouraged and does add additional income to your other income account. Store Management must approve the store's participation and placement on the parking lot.

Thank you in advance for your cooperation in this matter and if you have any questions, please contact TNT Fireworks at 256-767-7142.

Best Regards,

DocuSigned by:

3CEEF3D9BFFA44F...
Pete Rosen
Walmart Retail Services

Any questions or concerns:
David Midgorden
District Manager
SOUTH/SOUTH EASTERN GA, EASTERN SC, NORTH FL ~
Cell: 912-271-9772
Email: midgordend@tntfireworks.com

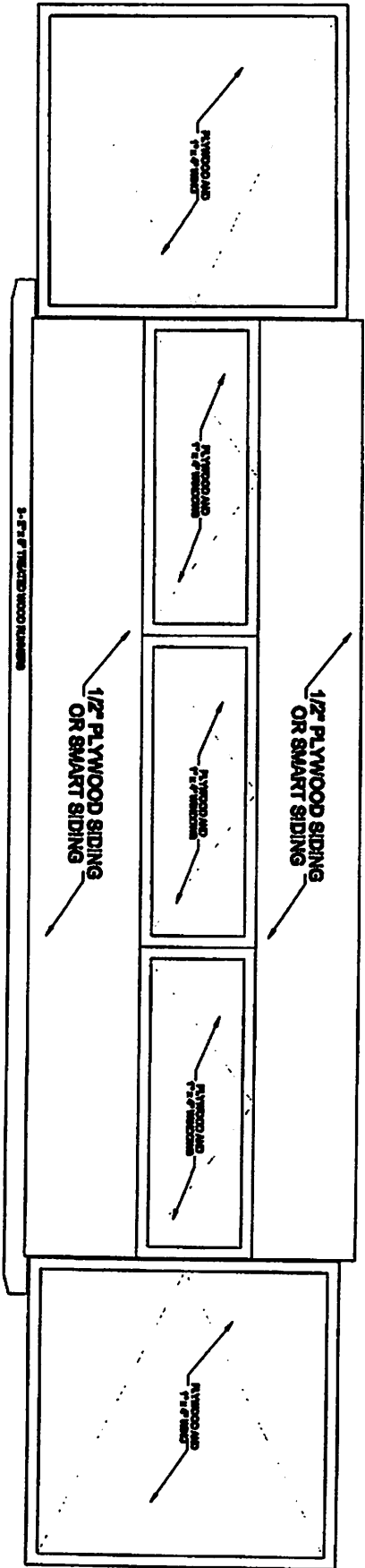

FRONT ELEVATION

TNT FIREWORK STAND

THIS DRAWING TO BE USE WITH STAMPED
DRAWINGS PROVIDED BY ARCHITECT

OWNER RESPONSIBLE FOR COMPLIANCE WITH CODES & OBTAINING APPROVAL OF LOCAL AUTHORITIES
 HILL & LANGRISH ARCHITECTS, P.C. PROVIDED DRAWING SERVICES
 ONLY OF AMERICAN PROMOTIONAL EVENTS, INC. DESIGN

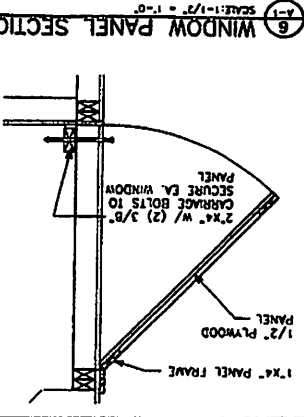
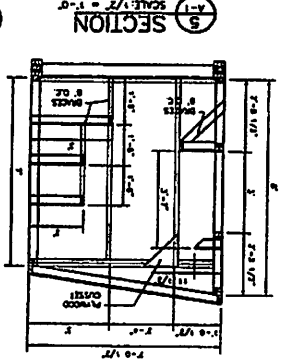
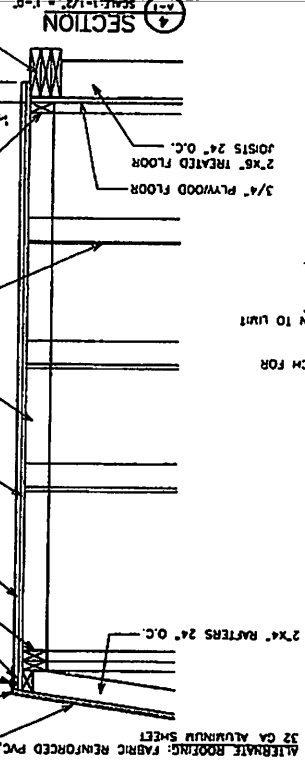
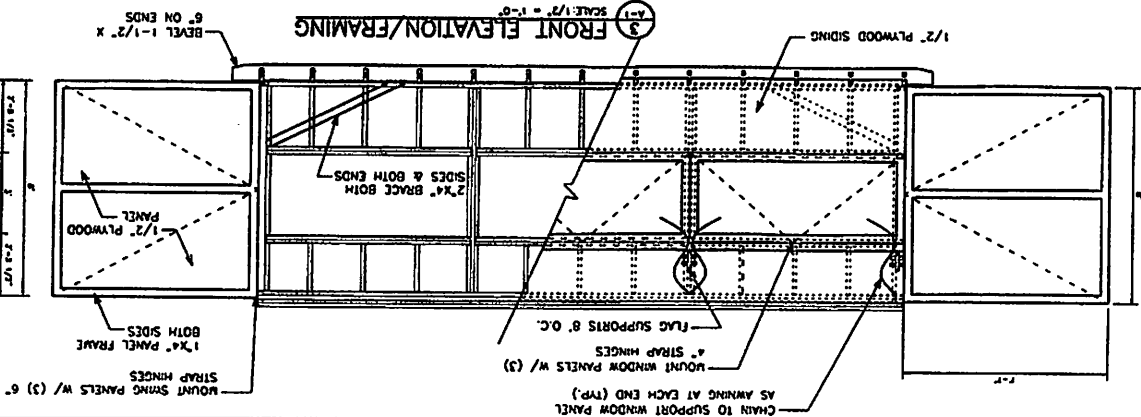
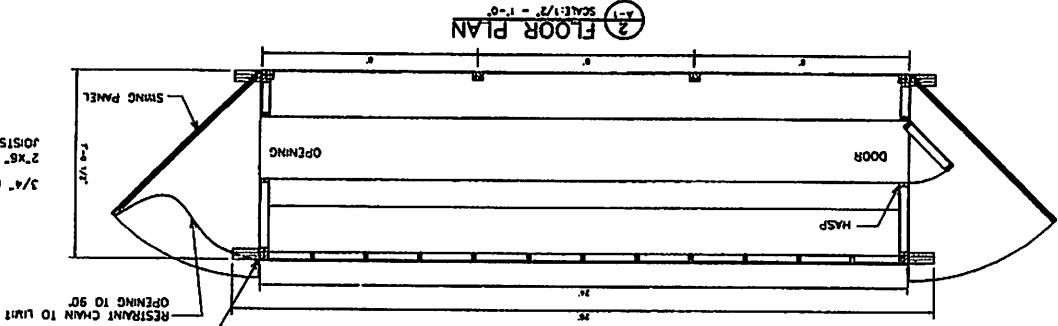
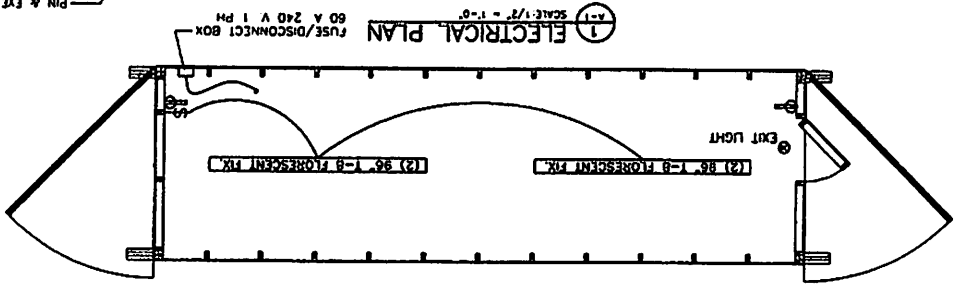

- ALTERNATE ROOFING: FABRIC REINFORCED PVC.
- 3/2 GA ALUMINUM SHEET
- PLYWOOD SHEATHING LAP EPDM
- AT CORNERS
- 4"x4" ALUM. 1 26 GA.
- EPDM ROOFING OVER 1/2"
- EPDM ROOFING TERMINATION BAR
- CONTINUOUS ALL 4 SIDES
- 1"x2" WOOD BLOCKING
- DOUBLE 2"x4" TOP PLATE
- 3/2 GA WHITE ALUMINUM SIDING
- BACK & ENDS ONLY W/ FORNED
- OUTSIDE CORNERS
- 1/2" PLYWOOD SHEATHING
- 2"x4" RAFTERS 24" O.C.
- 2"x4" STUD FRAMING 24" O.C.
- 1/2" PLYWOOD SHEATHING (TRP.)
- 2"x4" SILL
- 3/4" PLYWOOD FLOOR
- 2"x6" TREATED FLOOR JOISTS 24" O.C.
- (3) 2"x6" TREATED SKID

HILL & LANGRISH ARCHITECTS, P.C.
 2400 W. 10TH STREET, SUITE 200, DENVER, CO 80202
 REGISTERED ARCHITECTS, STATE OF COLORADO
 AMERICAN PROMOTIONAL EVENTS, INC.
 RETAIL STAND

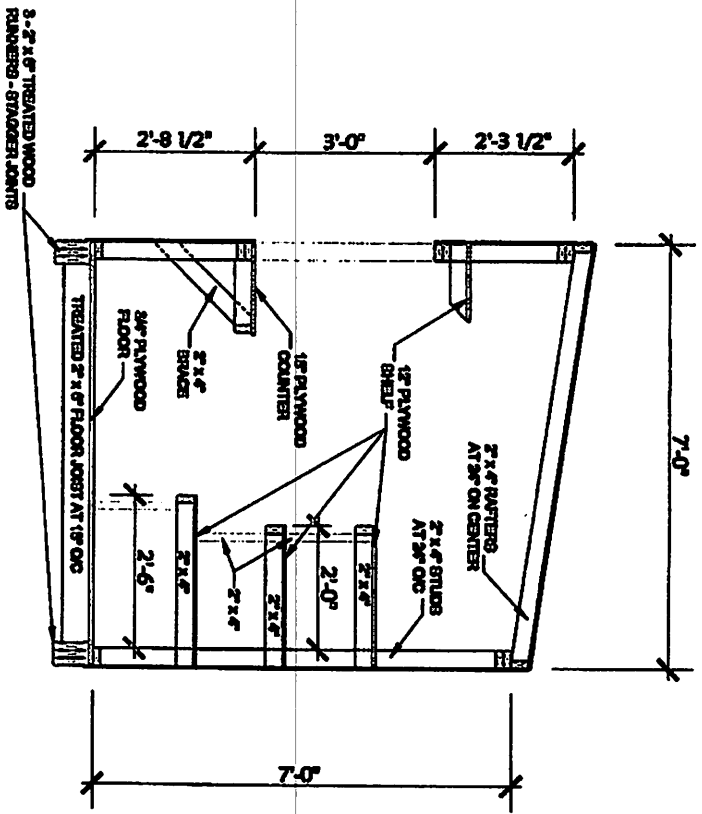

SECTION

TNT FIREWORK STAND

THIS DRAWING TO BE USE WITH STAMPED
DRAWINGS PROVIDED BY ARCHITECT

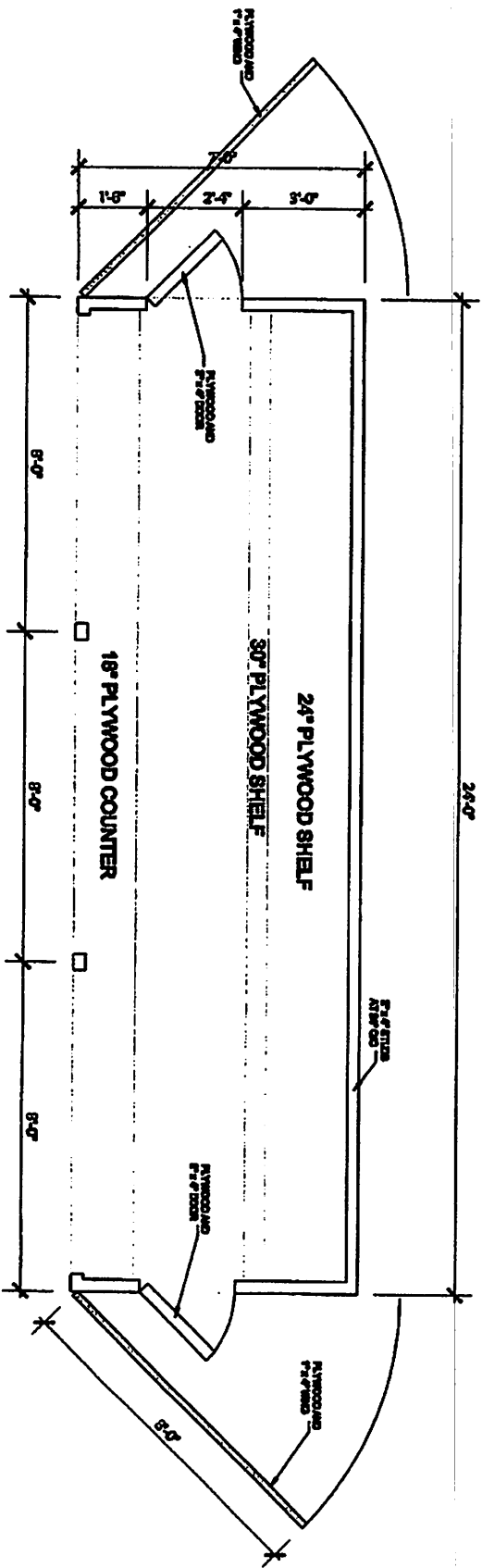

FLOOR PLAN

TNT FIREWORK STAND

THIS DRAWING TO BE USE WITH STAMPED
DRAWINGS PROVIDED BY ARCHITECT

Walmart # 5709
FGA5709
4949 BILL GARDNER PKWY
LOCUST GROVE, GA 30248

Google earth
©2016 Google



Legend



CERTIFICATE OF LIABILITY INSURANCE

11/1/2023

DATE (MM/DD/YYYY)

11/1/2022

THIS CERTIFICATE IS ISSUED AS A MATTER OF INFORMATION ONLY AND CONFERS NO RIGHTS UPON THE CERTIFICATE HOLDER. THIS CERTIFICATE DOES NOT AFFIRMATIVELY OR NEGATIVELY AMEND, EXTEND OR ALTER THE COVERAGE AFFORDED BY THE POLICIES BELOW. THIS CERTIFICATE OF INSURANCE DOES NOT CONSTITUTE A CONTRACT BETWEEN THE ISSUING INSURER(S), AUTHORIZED REPRESENTATIVE OR PRODUCER, AND THE CERTIFICATE HOLDER.

IMPORTANT: If the certificate holder is an ADDITIONAL INSURED, the policy(ies) must have ADDITIONAL INSURED provisions or be endorsed. If SUBROGATION IS WAIVED, subject to the terms and conditions of the policy, certain policies may require an endorsement. A statement on this certificate does not confer rights to the certificate holder in lieu of such endorsement(s).

PRODUCER Lockton Companies 3280 Peachtree Road NE, Suite #250 Atlanta GA 30305 (404) 460-3600	CONTACT NAME: _____	
	PHONE (A/C, No, Ext): _____	FAX (A/C, No): _____
	E-MAIL ADDRESS: _____	
	INSURER(S) AFFORDING COVERAGE	NAIC #
	INSURER A : Everest Indemnity Insurance Company	10851
INSURED 1359629 American Promotional Events, Inc. DBA TNT Fireworks, Inc. P.O. Box 1318 4511 Helton Drive Florence AL 35630	INSURER B : _____	
	INSURER C : _____	
	INSURER D : _____	
	INSURER E : _____	
	INSURER F : _____	

COVERAGES CERTIFICATE NUMBER: 12284330 REVISION NUMBER: XXXXXXXX

THIS IS TO CERTIFY THAT THE POLICIES OF INSURANCE LISTED BELOW HAVE BEEN ISSUED TO THE INSURED NAMED ABOVE FOR THE POLICY PERIOD INDICATED. NOTWITHSTANDING ANY REQUIREMENT, TERM OR CONDITION OF ANY CONTRACT OR OTHER DOCUMENT WITH RESPECT TO WHICH THIS CERTIFICATE MAY BE ISSUED OR MAY PERTAIN, THE INSURANCE AFFORDED BY THE POLICIES DESCRIBED HEREIN IS SUBJECT TO ALL THE TERMS, EXCLUSIONS AND CONDITIONS OF SUCH POLICIES. LIMITS SHOWN MAY HAVE BEEN REDUCED BY PAID CLAIMS.

INSR LTR	TYPE OF INSURANCE	ADDL INSD	SUBR WVD	POLICY NUMBER	POLICY EFF (MM/DD/YYYY)	POLICY EXP (MM/DD/YYYY)	LIMITS
A	<input checked="" type="checkbox"/> COMMERCIAL GENERAL LIABILITY <input type="checkbox"/> CLAIMS-MADE <input checked="" type="checkbox"/> OCCUR GEN'L AGGREGATE LIMIT APPLIES PER: <input type="checkbox"/> POLICY <input type="checkbox"/> PRO-JECT <input checked="" type="checkbox"/> LOC OTHER: _____	Y	N	S18GL00242221	11/1/2022	11/1/2023	EACH OCCURRENCE \$ 1,000,000 DAMAGE TO RENTED PREMISES (Ea occurrence) \$ 500,000 MED EXP (Any one person) \$ 5,000 PERSONAL & ADV INJURY \$ 1,000,000 GENERAL AGGREGATE \$ 2,000,000 PRODUCTS - COM/OP AGG \$ 2,000,000 \$
	<input type="checkbox"/> AUTOMOBILE LIABILITY <input type="checkbox"/> ANY AUTO <input type="checkbox"/> OWNED AUTOS ONLY <input type="checkbox"/> HIRED AUTOS ONLY <input type="checkbox"/> SCHEDULED AUTOS <input type="checkbox"/> NON-OWNED AUTOS ONLY			NOT APPLICABLE			COMBINED SINGLE LIMIT (Ea accident) \$ XXXXXXXX BODILY INJURY (Per person) \$ XXXXXXXX BODILY INJURY (Per accident) \$ XXXXXXXX PROPERTY DAMAGE (Per accident) \$ XXXXXXXX \$ XXXXXXXX
	<input type="checkbox"/> UMBRELLA LIAB <input type="checkbox"/> EXCESS LIAB <input type="checkbox"/> OCCUR <input type="checkbox"/> CLAIMS-MADE <input type="checkbox"/> DED <input type="checkbox"/> RETENTION \$			NOT APPLICABLE			EACH OCCURRENCE \$ XXXXXXXX AGGREGATE \$ XXXXXXXX \$ XXXXXXXX
	<input type="checkbox"/> WORKERS COMPENSATION AND EMPLOYERS' LIABILITY ANY PROPRIETOR/PARTNER/EXECUTIVE OFFICER/MEMBER EXCLUDED? (Mandatory in NH) If yes, describe under DESCRIPTION OF OPERATIONS below	<input type="checkbox"/> Y <input checked="" type="checkbox"/> N	N/A	NOT APPLICABLE			<input type="checkbox"/> PER STATUTE <input type="checkbox"/> OTH-ER E.L. EACH ACCIDENT \$ XXXXXXXX E.L. DISEASE - EA EMPLOYEE \$ XXXXXXXX E.L. DISEASE - POLICY LIMIT \$ XXXXXXXX

DESCRIPTION OF OPERATIONS / LOCATIONS / VEHICLES (ACORD 101, Additional Remarks Schedule, may be attached if more space is required)
Additional Insured: FGA5709; Property located at parking lot at 4949 Bill Gardner Parkway, Locust Grove, GA 30248; Faith Assembly #12 Inc; Certificate holder is an additional insured on the General Liability as required by written contract subject to policy terms, conditions, and exclusions.

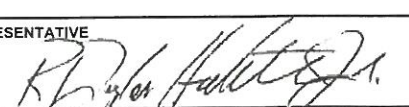
CERTIFICATE HOLDER 12284330 Walmart Stores, Inc. 702 SW 8th Street Bentonville AR 72716	CANCELLATION SHOULD ANY OF THE ABOVE DESCRIBED POLICIES BE CANCELLED BEFORE THE EXPIRATION DATE THEREOF, NOTICE WILL BE DELIVERED IN ACCORDANCE WITH THE POLICY PROVISIONS. AUTHORIZED REPRESENTATIVE 
---	--

© 1988-2016 ACORD CORPORATION. All rights reserved.



STATE OF GEORGIA
OFFICE OF

GEORGIA SAFETY FIRE COMMISSIONER

JOHN F. KING

COMMISSIONER OF INSURANCE
SAFETY FIRE COMMISSIONER

620 West Tower, 2 Martin Luther King, Jr. Drive
Atlanta, Georgia 30334

License No. **CFB21-000539**

Consumer Fireworks Distribution License

The following Branch Store, as defined in NFPA 1124, 2006, is authorized to sell Retail fireworks in accordance with the Rules and Regulations of the Safety Fire Commissioner, Chapter 120-3-22 and O.C.G.A. Section 25-10-5 under the license of it's main office as also defined in NFPA 1124, 2006, shown below.

License Holder:
TNT Fireworks
4511 Helton Drive
Florence, AL 35630

Store Name:
Wal-Mart #5709
4949 Bill Gardner Pkwy
Locust Grove GA 30248

This certificate is dependent on the status of the main office license. Provided that license remains in good standing, this certificate will expire on January 31, 2024

Maximum Poundage: 1000 lbs

By: 

CRAIG LANDOLT
INTERRIM FIRE MARSHALL



Administration Department

P. O. Box 900
Locust Grove, Georgia 30248

Phone: (770) 957-5043
Facsimile: (866) 364-0996

Item Coversheet

Item: Supplemental Lease Agreement – Equipment

Action Item: Yes No

Public Hearing Item: Yes No

Executive Session Item: Yes No

Advertised Date: N/A

Budget Item: Yes, General Fund; Street Maintenance and Sanitation

Date Received: June 1, 2023

Workshop Date: N/A

Regular Meeting Date June 5, 2023 / City Manager Comments

Discussion:

Attached is a Resolution to enter into agreement with United Bank for the lease-purchase of a new Morbark chipper in the amount of \$111,500 (with associated financing costs) for use in the chipping of limbs and trees throughout the city that will supplement our existing 2016-era chipper that, in the past year has seen more time in the shop than in use (also requiring us to rent one while out for repair). The new chipper is larger in capacity and strength, which will be useful should we have more natural disasters such as the past January. The rental payments will be just over \$26,000 annually to help smooth out the cost of the equipment purchase, as the price of chippers have increased dramatically from the original purchase at just under \$30,000 of the existing Bandit.

Recommendation:

APPROVE RESOLUTION FOR SUPPLEMENTAL LEASE AGREEMENT FOR THE LEASE - PURCHASE OF EQUIPMENT FOR USE IN SANITATION AND STREET MAINTENANCE PURPOSES.

RESOLUTION NO. _____

A RESOLUTION TO AUTHORIZE AND DIRECT AN OFFICER OF THE CITY OF LOCUST GROVE TO EXECUTE ONE OR MORE LEASE SUPPLEMENTS FOR A LEASE OR LEASES; TO DESIGNATE SUCH LEASES AS QUALIFIED TAX-EXEMPT OBLIGATIONS; TO PROVIDE AN EFFECTIVE DATE; AND FOR OTHER PURPOSES.

WHEREAS, The City is authorized to enter into contracts and agreements with other governments and entities and with private persons, firms, and corporations pursuant to Article 9, Section 4, Paragraph 2 of the Constitution of the State of Georgia, regarding the provision of services; and

WHEREAS, the City of Locust Grove has determined that a true and very real need exists for the acquisition of a 2023 Morbark 1821 173HP Diesel Engineer Chipper (the “Leased Property – Equipment”) and the City (“Lessee”) desires to finance the Equipment by entering into an Equipment Lease Purchase Agreement (“Agreement”) with United Bank (“Lessor”) according to the terms set forth in the Bid Proposal from United Bank, presented at the June 5, 2023 regular council meeting. The Equipment will be used for the purpose of general maintenance activities in Public Works, and more specifically use in both the Street Maintenance Department, the Stormwater Department for use in chipping and hauling off of limbs and tree debris; and,

WHEREAS, the City has taken the necessary steps, including any legal bidding requirements, under applicable law to arrange for the acquisition of such Equipment: and,

WHEREAS, the City of Locust Grove (“City”) has entered into a Master Lease (the “Master Lease”) dated as of August 14, 2020, with United Bank for the leasing from time to time of certain equipment, machinery, or other personal property pursuant to Supplemental Leases;

WHEREAS, the City directs its legal counsel to review the Agreement and negotiate appropriate modification to said Agreement so as to assure compliance with state land and local statutory law, prior to execution of the Agreement by those persons so authorized by the Lessee for such purpose Said Agreement is attached hereto as Exhibit “A” and made a part hereof; and

WHEREAS, the City wishes to authorize the Mayor to enter into and execute the Agreement and to authorize the City Clerk to attest signature and apply the City Seal on any necessary document; and

WHEREAS, the City finds that the foregoing action is necessary and beneficial to its citizens.

NOW THEREFORE, BE IT RESOLVED AS FOLLOWS BY THE GOVERNING BODY OF THE CITY:

SECTION 1. **Master Lease.** The Master Lease is hereby ratified and deemed to be in full force and effect. The Mayor of the City is hereby authorized and directed to execute and deliver a Lease Supplement pursuant to the Master Lease to put into effect one or more leases for a 2023 Morbark 1821 173HP Diesel Engineer Chipper (the “Leased Property – Equipment”) as attached hereto and incorporated herein by reference as **Exhibit “A”** is hereby approved; said officer of the City is authorized and directed in the name and on behalf of the City to execute and deliver (i) one or more Lease Supplements for items of the Leased Property in substantially the form attached to the Master Lease, with such changes and additions as may be approved by said officer, and (ii) such other documents as may be deemed by such officer to be necessary or desirable to effect the purposes hereof or of the Master Lease, and such execution shall constitute conclusive evidence that the executed document has been authorized and approved hereby; the aforesaid officer is further authorized to do all things necessary or appropriate to effectuate the purposes hereof.

SECTION 2. **Approval of Execution.** The terms of said Agreement are in the best interest of the Lessee for the acquisition of such Equipment and The Mayor is hereby authorized to execute the Agreement as described in **Exhibit "A"** upon verification of the contract as to form by the City Attorney, and the City Manager or his designee is authorized to take those actions necessary to effectuate this ordinance and perform the obligation of the City under said Agreement.

SECTION 3. **Appropriation and Tax Exempt Obligation.** An appropriation from unappropriated and unreserved funds in the City’s current operating budget is hereby made in the amount of \$52,886.50 for the “Rentals” and the “Termination Payment” during the “Starting Term” under such Lease Supplements, and the budget of the City is hereby amended to reflect such appropriation to the extent necessary.

The lease or leases contemplated by the said Lease Supplements are hereby designated “Qualified Tax-Exempt Obligations” within the meaning of Section 265(b)(3) of the Internal Revenue Code of 1986, as amended, and said officer shall be authorized to confirm such designation by execution of appropriate documents in connection therewith.

SECTION 4. **Documents.** The City Clerk is authorized to execute, attest to, and seal any documents which may be necessary to effectuate the Agreement.

SECTION 5. **Severability.** The preamble of this Ordinance is incorporated herein and made a part hereof by reference to same. In the event any portion of this ordinance shall be declared or adjudged invalid or unconstitutional, it is the intention of the City Council of Locust Grove that such adjudications shall in no manner affect the other sections, sentences, clauses, or phases of this ordinance which shall remain in full force and effect as if the invalid or unconstitutional section, sentence, clause or phrase were not originally part of the ordinance.

SECTION 6. **Repeal of conflicting provisions.** All ordinances or parts of ordinances in conflict with this ordinance are hereby repealed, except as otherwise provided herein, all ordinances or parts of ordinances in conflict with this ordinance are hereby repealed.

SECTION 7. **Effective date.** This ordinance shall become effective immediately upon its adoption by the Mayor and the City Council of Locust Grove.

SO ORDAINED by the Council of the City this 5th day of June, 2023.

ROBERT PRICE, Mayor

ATTEST:

APPROVED AS TO FORM:

MISTY SPURLING, City Clerk

CITY ATTORNEY

CLERK’S CERTIFICATE

The undersigned hereby certifies that he or she is the Clerk of the City of Locust Grove, Georgia (the “City”), and that the foregoing is a true copy of the Resolution adopted by the governing body of the City at a meeting duly held on the day of , 2023, at which a quorum was present and acting throughout, and that the same has not been rescinded or modified and is now in full force and effect. Given under the seal of the City, this the day of , 2023.

EXHIBIT A

LEASE SUPPLEMENT AGREEMENT

LEASE SUPPLEMENT

THIS LEASE SUPPLEMENT (hereinafter referred to as “Lease Supplement”) by and between **UNITED BANK**, a domestic banking corporation organized and existing under the laws of the State of Georgia, and its successors and assigns (hereinafter referred to as “Lessor”), and the **CITY OF LOCUST GROVE**, a Georgia municipal corporation (hereinafter referred to as “Lessee”), is made and entered into the date of its execution by Lessor.

RECITALS:

Lessor and Lessee have entered into a Master Lease (hereinafter referred to as the “Master Lease”), dated December 31, 2019, which provides for Lessor to lease to Lessee certain property (the “Property”) to be specified in Lease Supplements to be executed and delivered by lessor and Lessee from time to time; and

Lessor and Lessee are entering into this Lease Supplement pursuant to the Master Lease to specify the terms of the lease of certain Property.

LESSOR AND LESSEE HEREBY AGREE AS FOLLOWS:

1. Definitions. Unless a different meaning or intent is required by this Lease Supplement, the capitalized terms used in this Lease Supplement shall have the meanings set forth in the Master Lease.
2. Property. The Property described on the Property Schedule incorporated as Schedule A to this Lease Supplement is specified as the Property that initially is the subject hereof.
3. Lease Payments. The Rental Schedule, incorporated as Schedule B to this Lease Supplement describes the initial amounts and payment dates of the Rentals for the Lease, and the Purchase Price for the Property. The Termination Payment may become due and payable upon the circumstances described in Section 4.2 of the Master Lease.
4. Term of Lease. The Starting Term of the lease of the Property shall begin on the date hereof (the “Starting Date”) and end on December 31 of the same year. The Lease will be renewed for successive calendar year Renewal Terms (the “Renewal Terms”), and an Ending Term (the “Ending Term”) commencing January 1 of the last calendar year appearing on the Rental Schedule, and ending on the date of the final payment shown on the Rental Schedule (the “Ending Date”), unless Lessee gives a Nonrenewal Notice or there occurs an Event of Non-appropriation, as provided in the Master Lease. The “Lease Term” is the period from the Starting Date to the Ending Date, subject to the earlier expiration or termination of the Lease as provided in the Master Lease.
5. Agreements, Representations and Warranties. Lessee represents, warrants and agrees as follows:
 - (a) Lessee’s representations, warranties and agreements contained in the Master Lease are true, accurate, complete and effective as of the date hereof;

(b) (This clause (b) applies only if this Lease is designated as a Bank-Qualified Lease below). In order to enable Lessor to offer the interest rate contained in this Lease, Lessee represents and warrants that it has not issued, nor does it (taken together with the entities with which it must aggregate pursuant to Section 265(b)(3)(E) of the Code) reasonably expect to issue (taking into account the Leases) more than Ten Million Dollars (\$10,000,000.00) of tax-exempt obligations (other than private activity bonds) for the calendar year during which the Lease becomes effective; as provided in Code Section 265(b)(3)(B)(II), Lessee specifically designates the Lease as a “qualified tax-exempt obligation” as provided by Code Section 265(b)(3);

(c) Lessee will take no action that will directly or indirectly affect the deductibility of that portion of Lessor’s interest expense allocable to this Lease;

(d) Lessee has made an available appropriation of and included in its current operating budget all Rentals for the Starting Term and the Termination Payment applicable to this Lease;

(e) Lessee has received, tested, and finally accepted the Property;

(f) The portion of the Rentals representing principal, when taken together with the principal portion outstanding under any other contract entered into by Lessee pursuant to the authority of O.C.G.A § 36-60-13, together with the amount of debt outstanding incurred by Lessee pursuant to Article IX, Section V, Paragraph I of the Constitution of Georgia of 1983, as amended, does not exceed ten percent (10%) of the assessed value of all taxable property within the jurisdictional limits of Lessee;

(g) The Property that is the subject hereof has not been the subject of a referendum that failed to receive the approval of the voters of Lessee within the calendar year in which this Lease is entered into for any of the four immediately preceding calendar years;

(h) If the Property subject to this Lease is real property, and unless the Property has been approved in the most recent referendum calling for the levy of a special county One percent (1%) sales and use tax pursuant to O.C.G.A Title 48, Chapter 8, Article 3, Part 1, neither of the following has occurred:

(i) The average annual payments on the aggregate of all outstanding contracts entered into by Lessee for real property pursuant to the authority of O.C.G.A § 36-60-13, including this Lease, do not exceed Seven and One-Half percent (7.5%) of the governmental fund revenues of Lessee for the last calendar year preceding the date of delivery of this Lease (provided, however, that there may be added to such governmental fund revenues any special county One percent (1%) sales and use tax proceeds collected pursuant to O.C.G.A § 48-8-111 legally available to pay amounts on this Lease or such other contracts); and

(ii) The outstanding principal balance on the aggregate of all outstanding contracts entered into by lessee for real property pursuant to the authority of O.C.G.A § 36-60-13 including this Lease does not exceed Twenty Five Million Dollars (\$25,000,000.00);

(i) If the property subject to this Lease is real property, Lessee held a public hearing with respect to this Lease prior to the delivery of this Lease, notice of which hearing was published at least once in each of the two weeks preceding the week of the hearing in a newspaper of general circulation in the jurisdiction of Lessee;

(j) No Event of Default or Event of Non-appropriation has occurred with respect to any Lease entered into under the Master Lease.

6. Non-Arbitrage Certificate. The property that is subject to the Lease has not been and is not expected to be sold or otherwise disposed of in whole or in part prior to the Ending Date. Monies appropriated for the payment of amounts under the Lease will be paid from Lessee's general fund and will not be pledged for the Lease or be otherwise separately identified or accounted for (unless the Lease is to be paid from sales tax receipts). Lessee has not been notified of any listing of it by the Internal Revenue Service as an issuer that may not certify its obligations. No proceeds or "gross proceeds" of the Lease are expected to be invested prior to an allocation for governmental use, unless an Escrow Agreement has been entered into in connection with this Lease. The proceeds of the Lease will not be used in a manner or no other action will be taken or omitted that would cause the Lease to be an "arbitrage bond" under Section 148 or a "private activity bond" under Section 141 of the Internal Revenue Code of 1986, as amended and the regulations promulgated under the Section.

7. Quitclaim. At the outset of this Lease, the Lessee does hereby assign, transfer, convey and quitclaim to United Bank ("Lessor") such ownership interest as it may possess, if any, in and to the "Property", as is necessary to permit the Property to be leased by Lessor to Lessee pursuant to the terms of this Lease Supplement and the Master Lease in accordance with their terms. Pursuant to Section 2.2 of the Master Lease, Lessor further transfers title to Lessee to the extent provided therein, and Lessee accepts such transfer in accordance with such Section 2.2. This quitclaim is given in consideration of the advance by or on behalf of the Lessor of the purchase price of the Property and the undertaking of the Lessor represented by this Lease Supplement.

8. Active Municipality. The Lessee certifies that it does, and expects to continue (a) providing at least three of the following services, either directly or by contract: Law enforcement; fire protection (which may be furnished by a volunteer fire force) and fire safety; road and street construction or maintenance; solid waste management; water supply or distribution or both; waste-water treatment; storm-water collection and disposal; electric or gas utility services; enforcement of building, housing, plumbing, and electrical codes and other similar codes; planning and zoning; recreational facilities; (b) holding at least six (6) regular, monthly or bimonthly, officially recorded public meetings each year; and (c) qualifying for and holds a regular municipal election as provided by law.

9. Effect of Lease Supplement. This Lease Supplement is intended as a separate Lease of the items of Property described in this Lease Supplement pursuant to the Master Lease. The terms, conditions and provisions of the Master Lease are hereby incorporated in this Lease Supplement to the same extent as if fully set forth in this Lease Supplement in this place, except to the extent expressly amended or modified by this Lease Supplement. The owner of Lessor's interest in this Lease shall have all rights, powers and remedies of Lessor with respect to this Lease under the Master Lease. This Lease Supplement may be

executed in multiple counterparts, each of which shall constitute an original. This Lease Supplement shall be effective only upon the due completion and execution of the Schedules listed below and the delivery thereof to the Servicer.

10. Bank-Qualified or Non-Bank-Qualified.

The Lease under this Lease Supplement is a Non-Bank-Qualified Lease;

OR (check 1 box)

The Lease under this lease Supplement is a Bank-Qualified Lease and Lessee has designated the Lease under the Lease Supplement as a “qualified tax-exempt obligation” under Section 265(b)(3) of the Code. The Lessee and its subordinate entities, and the entities that issue obligations on behalf of Lessee have not issued other tax-exempt obligations (other than private activity bonds, excepted Qualified 501(c)(3) Bonds) in the current calendar year, and Lessee does not expect that it and such other entities will issue such tax-exempt obligations such that all of such obligations, taken together with the Lease Amount under the Lease Supplement, would exceed \$10,000,000.00 in such calendar year. The only tax-exempt obligations issued or expected to be issued in the current calendar year by such parties are as follows (type title, date and amount):

TITLE	DATE	AMOUNT
-------	------	--------

NONE

11. Payments Direction. Lessee authorizes and directs the Lessor or Servicer, if any, under this Lease Supplement to pay the Vendors of the Property as indicated below:

<u>NAME AND ADDRESS OF VENDOR</u>	<u>INVOICE #</u>	<u>AMOUNT</u>
Ag-Pro 2661 N Columbia Street Milledgeville, GA 31061	28255351	\$111,500.00

(Should Lessee have previously paid vendor, or require another means of payment to the Vendor, it should attach a request for an alternate payment method with a full explanation and, if applicable, proof of payment to the vendor.)

12. Schedules. Lessee hereby delivers to Lessor and its assigns the completed, executed and effective Schedules C, D, and E, described below.

IN WITNESS WHEREOF, Lessor and Lessee have caused this Lease Supplement to be duly executed as of June 7, 2023.

LESSEE
(SEAL)

CITY OF LOCUST GROVE

By: _____
Robert Price
Title: Mayor

Attested by: _____
Misty Spurling
Title: City Clerk

Date of Execution: _____

LESSOR
(SEAL)

UNITED BANK

By: _____
Title:

Date of Execution: _____

SCHEDULES HERETO

- A. PROPERTY SCHEDULE**
- B. RENTAL SCHEDULE**
- C. APPROPRIATION CERTIFICATE FORM**
- D. FORM 8038G or 8038GC**
- E. FORM UCC-1 (If included)**
- F. RESOLUTION FOR LEASE SUPPLEMENT**
- G. ASSIGNMENT AND TRANSFER OF LEASE SUPPLEMENT (if applicable)**

SCHEDULE A

PROPERTY SCHEDULE

DESCRIPTION OF PROPERTY	IDENTIFICATION OR VIN NUMBER	AMOUNT FINANCED
----------------------------	---------------------------------	-----------------

Morbark 1821 173HP Diesel Engine Chipper	Frame Serial No. 4S8SZ1912PW026648 Engine Serial No. PE40454153928	\$ 111,500.00
---	---	---------------

\$ 111,500.00

SCHEDULE B

**UNITED BANK GOVERNMENTAL FINANCE
AMORTIZATION SCHEDULE**

SEE ATTACHED

SCHEDULE C

APPROPRIATION CERTIFICATE

Re: Master Lease dated December 31, 2019 and Lease Supplement (the "Lease Supplement" dated June 7, 2023, between Lessee and Lessor.

The undersigned officers of the City of Locust Grove, Georgia (the "Lessee") hereby certify that all Rentals and the Termination Payment under the referenced Lease Supplement, for the current fiscal year are within such Lessee's operating budget or budgets for such year and an appropriation of funds for such year has been made for such purpose and will be available therefore at the times and in the amounts required in accordance with the provisions of the above-referenced Lease Supplement.

Dated: June 7, 2023

LESSEE
(SEAL)

CITY OF LOCUST GROVE

By: _____
Robert Price
Title: Mayor

Attested by: _____
Misty Spurling
Title: County Clerk

SCHEDULE D

FORM 8038 OR 8038GC

SCHEDULE E

RESOLUTION FOR SUPPLEMENTAL LEASES

AMORTIZATION SCHEDULE

Principal \$111,500.00	Loan Date 06-07-2023	Maturity 06-07-2028	Loan No 58019421	Call / Coll 8 / 414	Account CAA1255	Officer ***	Initials
References in the boxes above are for Lender's use only and do not limit the applicability of this document to any particular loan or item. Any item above containing "*****" has been omitted due to text length limitations.							

Borrower: City of Locust Grove
PO Box 900
Locust Grove, GA 30248-0900

Lender: United Bank
P.O. Box 160
Barnesville, GA 30204
(770) 567-7211

Disbursement Date: June 7, 2023
Interest Rate: 5.875

Repayment Schedule: Installment
Calculation Method: 365/360 U.S. Rule

Payment Number	Payment Date	Payment Amount	Interest Paid	Principal Paid	Remaining Balance
1	06-07-2024	26,443.25	6,659.80	19,783.45	91,716.55
2	06-07-2025	26,443.25	5,463.19	20,980.06	70,736.49
3	06-07-2026	26,443.25	4,213.49	22,229.76	48,506.73
4	06-07-2027	26,443.25	2,889.35	23,553.90	24,952.83
5	06-07-2028	26,443.24	1,490.41	24,952.83	0.00

TOTALS: **132,216.24** **20,716.24** **111,500.00**

NOTICE: This is an estimated loan amortization schedule. Actual amounts may vary if payments are made on different dates or in different amounts.



Administration Department

P. O. Box 900
Locust Grove, Georgia 30248

Phone: (770) 957-5043
Facsimile: (866) 364-0996

Item Coversheet

Item: July 17, 2023 Meeting Postponement to July 24, 2023

Action Item: Yes No

Public Hearing Item: Yes No

Executive Session Item: Yes No

Advertised Date: N/A

Budget Item: N/A

Date Received: June 1, 2023

Workshop Date: N/A

Regular Meeting Date June 5, 2023 / City Manager Comments

Discussion:

Our scheduled retreat is to be held on July 16 – July 19, 2023 regarding our existing and FY 24 Budget along with other items under development regarding government structure, capital improvements, the CID created for the NW side of I-75 in the Price Road corridor, and Future Land Use/Zoning related items.

The typical workshop would be held July 17, 2023 and would need to be postponed to July 24, 2023 (there is a 5th Monday in July which would not upset the typical hearing schedule. This postponement would allow timing of ads for notification and related actions to be moved to that new hearing date.

Recommendation:

APPROVE POSTPONEMENT OF THE JULY 17, 2023 WORKSHOP TO JULY 24, 2023.